

 **PIONEER®**

# Service Manual

**CIRCUIT DESCRIPTIONS  
REPAIR & ADJUSTMENTS**

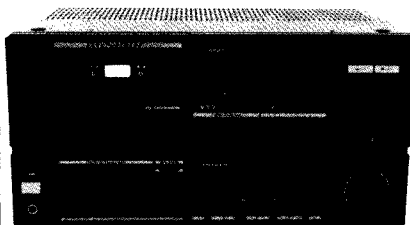

**ORDER NO.  
ARP-716-0**

**STEREO CASSETTE TAPE DECK AMPLIFIER**

# DC-X11Z DC-X10Z

(Silver Version of DC-X11Z)

- DC-X11Z is the same as the DC-X10Z except for the design (color) only.
- Models DC-X11Z and DC-X10Z come in versions distinguishes as follows:

Type	Applicable model		Power requirement	Destination
	DC-X11Z	DC-X10Z		
HE	○	○	AC220V (240V)*	European continent
HB	○	○	AC240V (220V)*	United Kingdom
YP	○	—	AC240V (220V)*	Australia
HEZ	○	—	AC220V (240V)*	West Germany
KU	○	—	AC120V only	U.S.A.
S	○	○	AC110V/120V/220V/240V (switchable)	General market

\* Change the primary wiring of the power transformer.

- This service manual is applicable to the HE and HB types.
- As to the KU, S and YP types, please refer to the additional service manual (ARP-717-0).
- As to the HEZ type, please refer to the additional service manual (ARP-718-0).
- Ce manuel d'instruction se refere au mode de réglage, en français.
- Este manual de servicio trata del método ajuste escrito español.

**PIONEER ELECTRONIC CORPORATION** 4-1, Meguro 1-Chome, Meguro-ku, Tokyo 153, Japan  
**PIONEER ELECTRONICS (USA) INC.** P.O. Box 1760, Long Beach, California 90801 U.S.A.  
TEL: (800) 421-1404, (800) 237-0424  
**PIONEER ELECTRONIC (EUROPE) N.V.** Keetberglaan 1, 2740 Beveren, Belgium TEL: 03/775-28-08  
**PIONEER ELECTRONICS AUSTRALIA PTY. LTD.** 178-184 Boundary Road, Braeside, Victoria 3195, Australia  
TEL: (03) 580-9911

SH©FEB. 1985 Printed in Japan

# CONTENTS

1. SPECIFICATIONS .....	2	8. SCHEMATIC DIAGRAM .....	27
2. FRONT PANEL FACILITIES .....	3	9. BLOCK DIAGRAM .....	31
3. DISASSEMBLY .....	4	10. CIRCUIT DESCRIPTIONS .....	32
4. PARTS LOCATION .....	9	11. ADJUSTMENTS .....	33
5. EXPLODED VIEW .....	11	RÉGLAGE .....	38
6. ELECTRICAL PARTS LIST .....	19	AJUSTE .....	43
7. P.C. BOARDS CONNECTION DIAGRAM .....	23	12. PACKING .....	48

## 1. SPECIFICATIONS

**Continuous Average Power Output is 25 Watts\* per channel, min., at 8 ohms from 40 Hertz to 20,000 Hertz, with no more than 0.3% total harmonic distortion.**

*\*Measured pursuant to the Federal Trade Commission's Trade Regulation rules on Power Output Claims for Amplifiers.*

<b>Continuous Power Output</b>	
40 to 20,000Hz .....	25 W + 25 W (T.H.D. 0.3% 8 ohms)
1 kHz (DIN) .....	32 W + 32 W (T.H.D. 1% 8 ohms)
1 kHz (DIN music power) .....	45 W + 45 W (T.H.D. 1% 8 ohms)
<b>Hum and Noise (IHF, short-circuited, A network)</b>	
PHONO .....	72 dB
<b>Hum and Noise (DIN continuous Power/50 mV)</b>	
PHONO .....	68 dB/60 dB
<b>Total Harmonic Distortion (40 Hz to 20,000 Hz, 8 ohms), from CD/VIDEO</b>	
12.5 Watts per channel power output .....	No more than 0.2%

### Tape Deck Section

Systems .....	4 track, 2-channel stereo
Heads .....	"Hard Permalloy" recording/playback head x 1
	"Hard Permalloy" playback head x 1
	"Ferrite" erasing head x 1
	Dummy head x 1
Motor .....	DC servo motor x 1
Wow and Flutter .....	No more than 0.08% (WRMS)
	No more than ±0.20% (DIN)
Fast Winding Time .....	Approximately 115 seconds (C-60 tape)
<b>Frequency Response</b>	
-20 dB recording:	
Normal tape .....	35 to 13,000 Hz
Metal tape .....	35 to 15,000Hz
<b>Signal-to-Noise Ratio</b>	
Dolby NR OFF .....	More than 55 dB
<b>Noise Reduction Effect</b>	
Dolby NR ON .....	More than 10 dB (at 5 kHz)

### Furnished Parts

Operating Instructions .....	1
------------------------------	---

### Miscellaneous

#### Power requirements

KU and KC models .....	AC 120 V, 60 Hz
HE model .....	AC 220 V, 50/60Hz
HB and YP models .....	AC 240 V, 50/60 Hz
S and S/G models .....	AC 110 V/120 V/220 V/240 V, 50/60 Hz (switchable)

#### Power Consumption

KU model .....	199 W
KC model .....	199 W
HE, HB, and YP models .....	270 W
S and S/G models .....	199 W
Dimensions .....	360(W) x 188(H) x 224 (D) mm
	14-3/16(W) x 7-6/16(H) x 8-13/16(D) in

Weight (without package) .....	5.5 kg (12 lb 2 oz)
--------------------------------	---------------------

QUESTIONNAIRE

MODEL \_\_\_\_\_

One Model per questionnaire

Dear Servicer,

Thank you for your cooperation in the post-sale service of Pioneer products.

This questionnaire is used as a tool to improve the serviceability of our products and service manuals. Please evaluate this model and service manual by answering the following questions. Your ideas may be realized in our future products. Your answers will be appreciated. Thank you.

PIONEER ELECTRONIC CORP.

T. Nakagawa, Manager, Service Section, International Division

1. SERVICING EVALUATION	Circle applicable number:	Good	Fair	Poor		
a. Disassembly/Re-assembly:		1	2	3	*4	*5
b. Circuit Checks:		1	2	3	*4	*5
c. Replacement of Parts:		1	2	3	*4	*5
d. Adjustment (s):		1	2	3	*4	*5

\* If (4) or (5) was circled, please be specific.

e. Your advice, opinion or ideas related to servicing this product.

**2. SERVICE MANUAL EVALUATION**

a. Circuit & Mechanism Description

b. Circuit Diagram

**3. OTHER**

Please describe other areas of servicing which you may find difficult.

Completed by :

Date :

Company Name :

Address :

City/State/Zip :

Please send this form filled to the distributor in your country.

## 2. FRONT PANEL FACILITIES

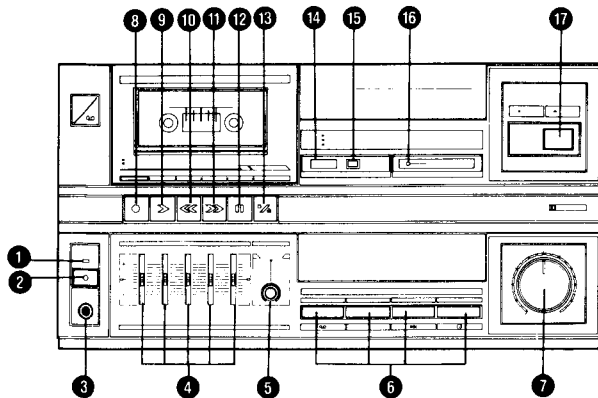

1 POWER indicator

2 POWER switch

3 HEADPHONES jack

4 5-BAND GRAPHIC EQUALIZER controls

By operating these five controls, equalization effects can be added to program source or tape playback sounds.

5 BALANCE control

6 FUNCTION switches

TAPE ( ∞ ): Push when playing back tapes.

CD/VIDEO ( ∞ ∞ ): Push when listening to a component connected to the CD/VIDEO terminals.

TUNER ( \* ): Push when listening to broadcasts on the tuner.

PHONO ( ∅ ): Push when playing records on the turntable.

7 VOLUME control

8 REC switch ( ∅ )

9 PLAY switch ( > )

10 REW switch ( <<< )

11 FF switch ( >>> )

12 PAUSE switch ( ∞∞ )

13 STOP/ EJECT switch ( ∞ )

14 TAPE COUNTER

15 RESET button

Push this button to reset the tape counter display to 000.

16 REC indicator

This lights during the recording mode.

17 \*DOLBY NR switch

Push this switch to ON when recording with the built-in Dolby noise reduction system, and when playing back tapes which have been recorded using the system.

~~~~~  
\*Noise Reduction manufactured under license from Dolby Laboratories Licensing Corporation.

"Dolby" and the double-D symbol are trademarks of the Dolby Laboratories Licensing Corporation.

~~~~~

### 3. DISASSEMBLY

#### Cassette Replacement Procedures

1. Remove 5 pieces of screw ①.
2. Remove Bonnet case.
3. Remove 2 pieces of screw ② and 1 piece of nut ②.
4. Push the claw at the bottom of chassis, remove the Front panel assembly, and pull out toward you. Remove the LED assembly (A) and (B) from the Front panel assembly.
5. Remove 6 pieces of screw ③, and enable the Power amplifier assembly to move upward. (See Fig. 3-2)
6. Remove connectors J7, J11 and J21 of the wiring coming out of the Tape transport unit. (Separate the Front panel assembly from the main body.)
7. Open the Cassette door. (See Fig. 3-3)
8. Remove 4 pieces of screw ④.
9. Remove Counter belt from Tape counter, and hook onto the Tape transport unit.
10. Remove the Tape transport unit from the Front panel assembly.

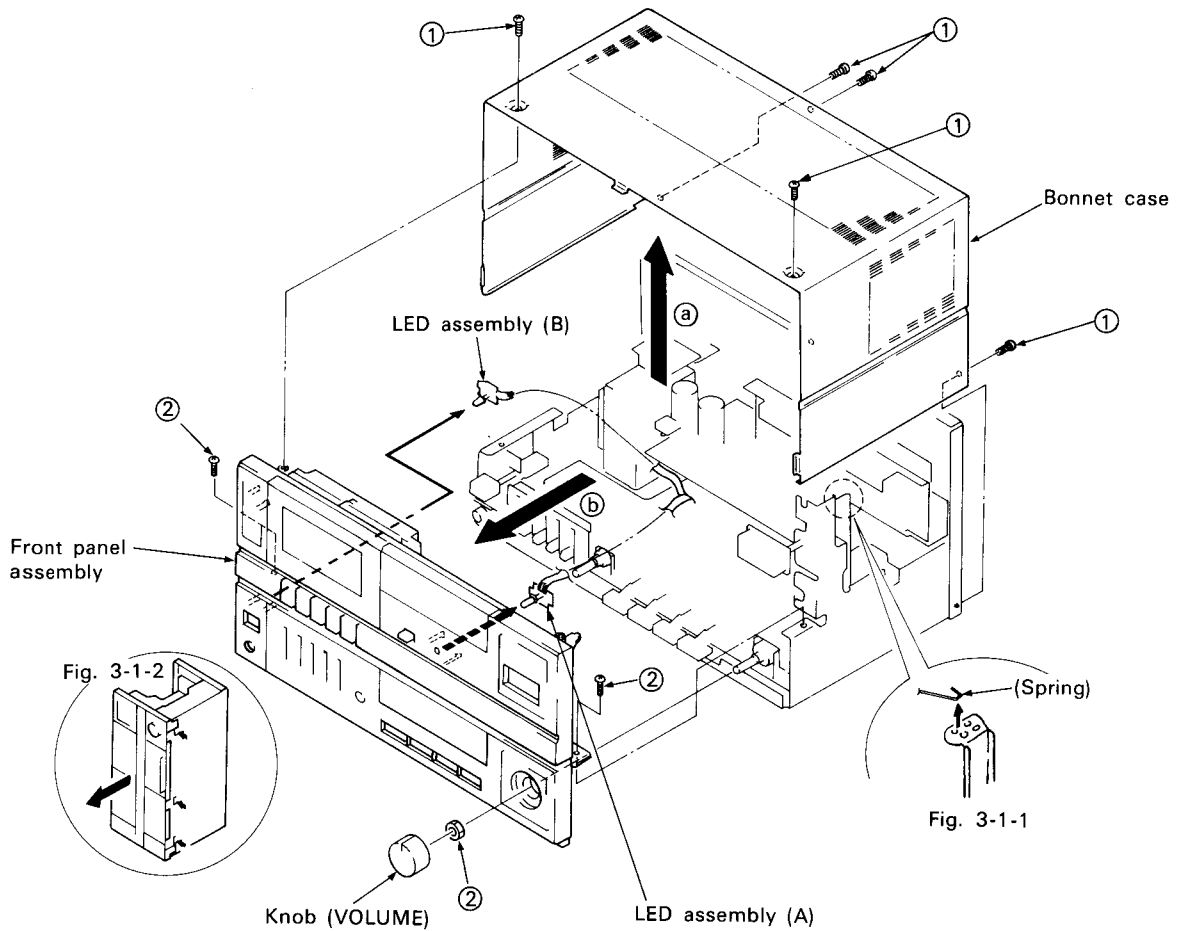

Fig. 3-1

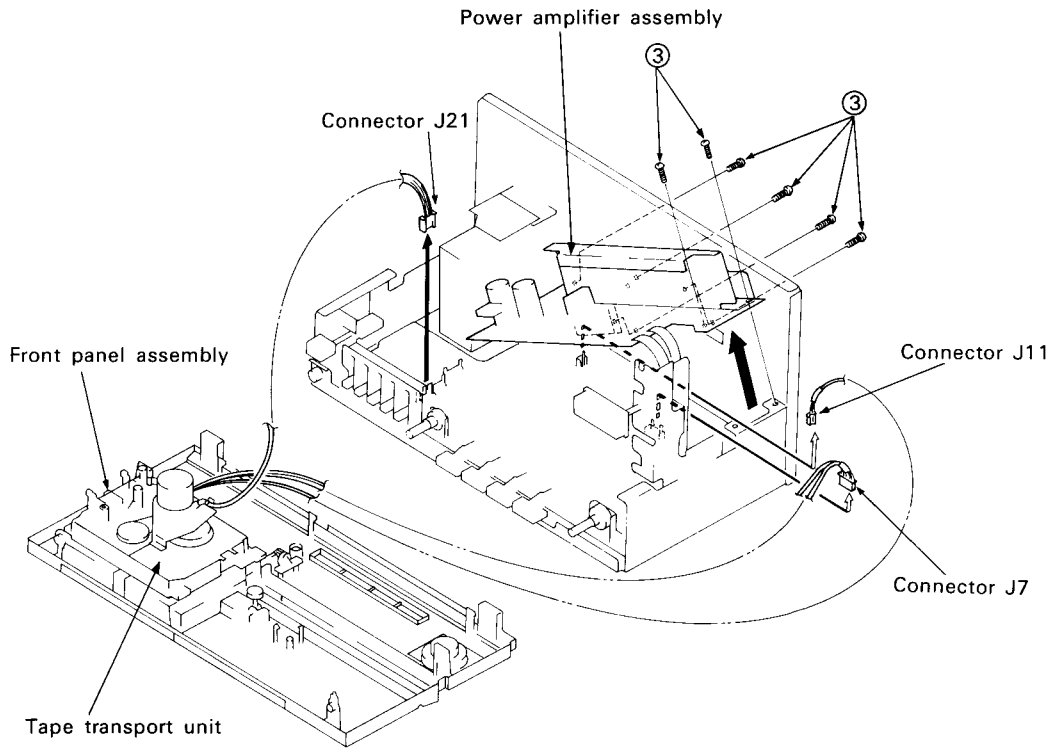

Fig. 3-2

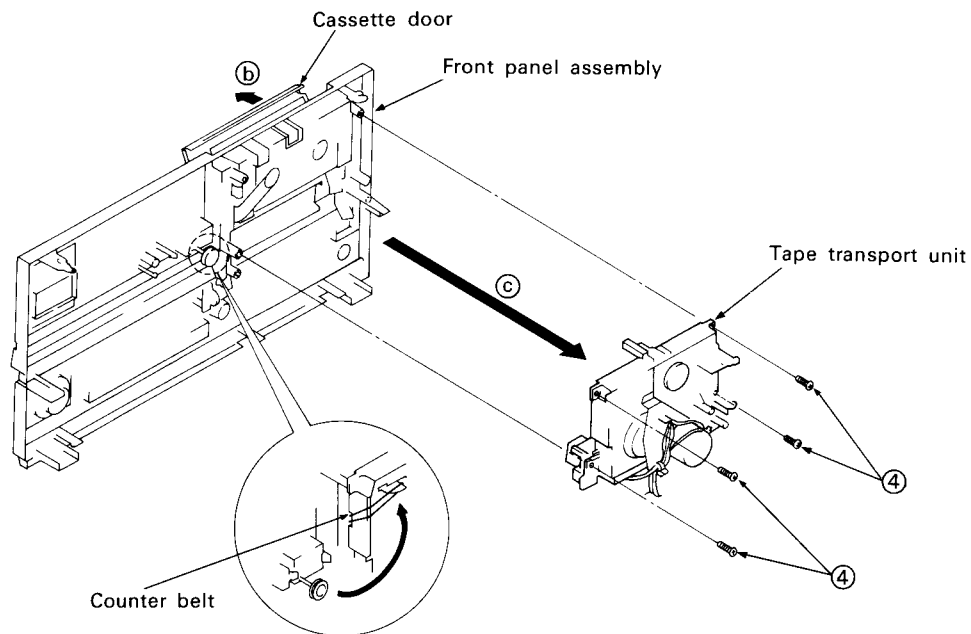

Fig. 3-3

**COMPONENT PARTS REPLACEMENT PROCEDURES**

**Replacement of Motor**

1. Remove lead wire of motor terminal.
2. Remove set screw ① and detach Motor holder.
3. Remove 2 set screws ②, and detach the Motor.
4. Pull out Motor pulley from Motor.
5. Attach Motor pulley to new motor.
6. Adjust the height of Motor pulley. (see Fig. 3-4-1)
7. Attach Motor to Motor holder.
8. While applying a Belt to the flywheel side, attach Motor plate to Tape transport unit.
9. Apply Belt to driving pulley and pulley.
10. Solder lead wire to motor terminal.
11. Fasten securely head lead and control lead with binder.
12. Adjust the tape speed.

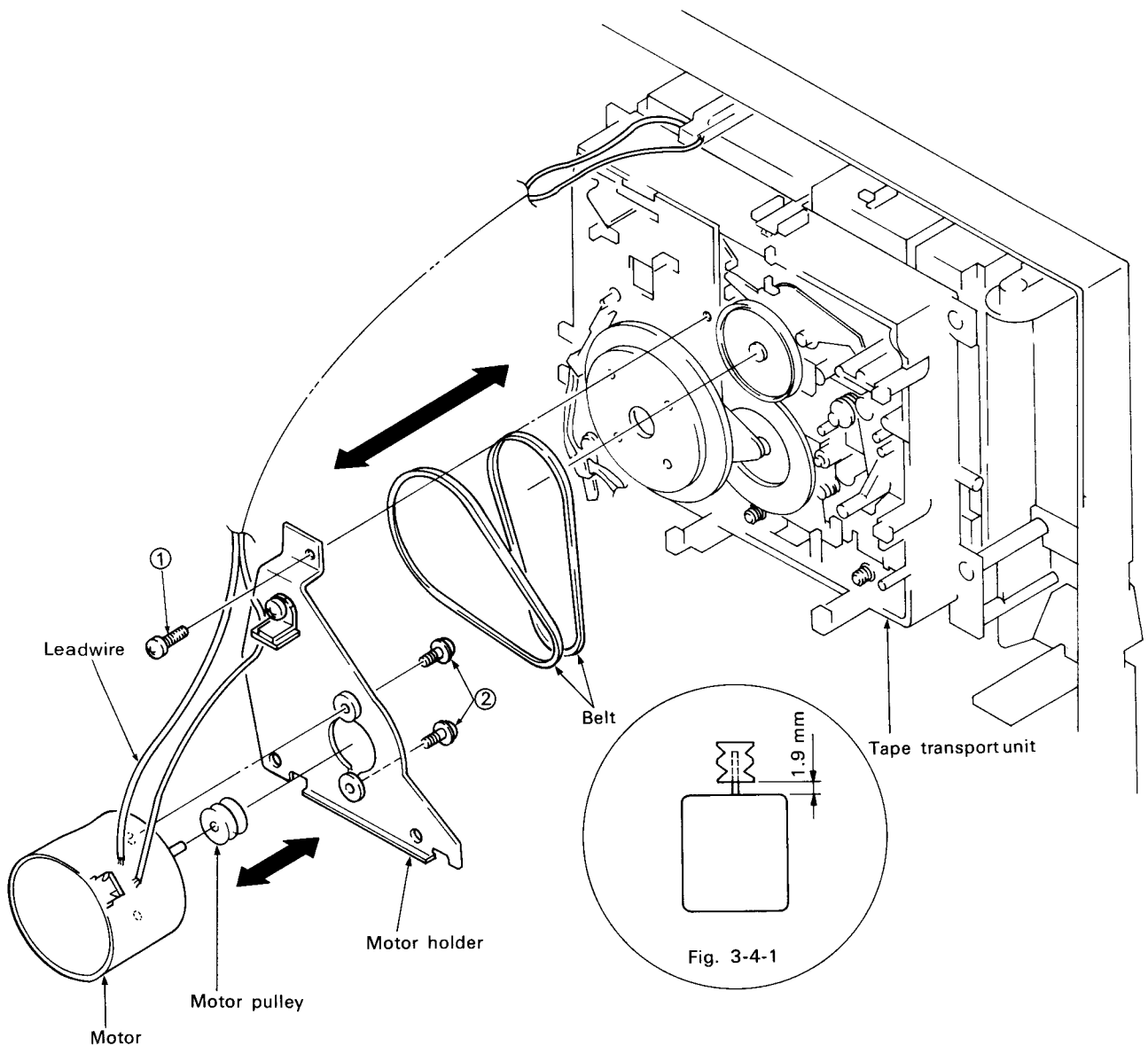

Fig. 3-4



**Replacement of Belt**

1. Remove set screw ① and detach Motor holder the Tape transport unit.
2. Replace the old belt with a new one.
3. While applying the Belt on the flywheel side, attach Motor holder to the Tape transport unit.
4. Apply belt to driving pulley and pulley.
5. Fasten securely head lead and control lead with binder.
6. Adjust the tape speed.

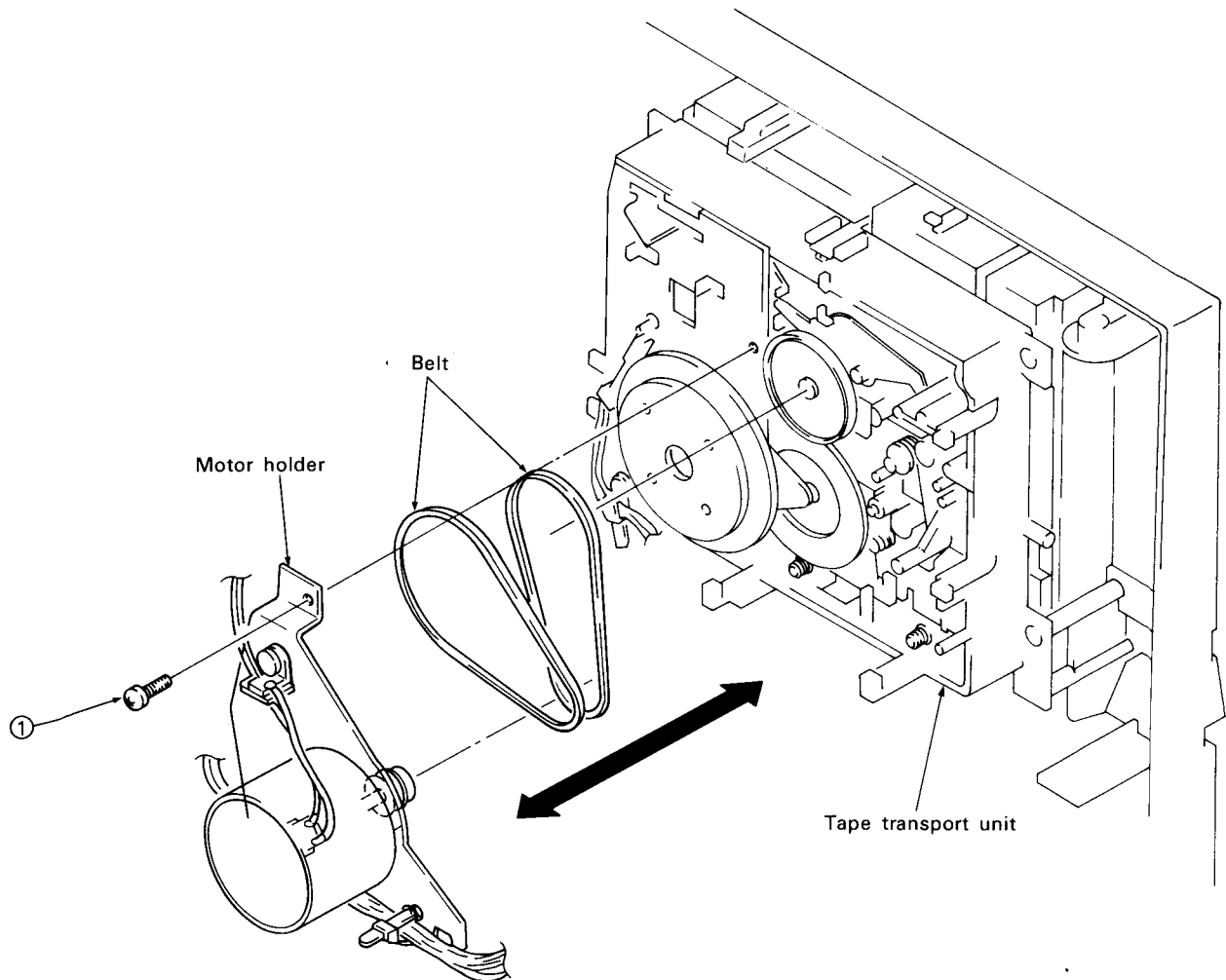
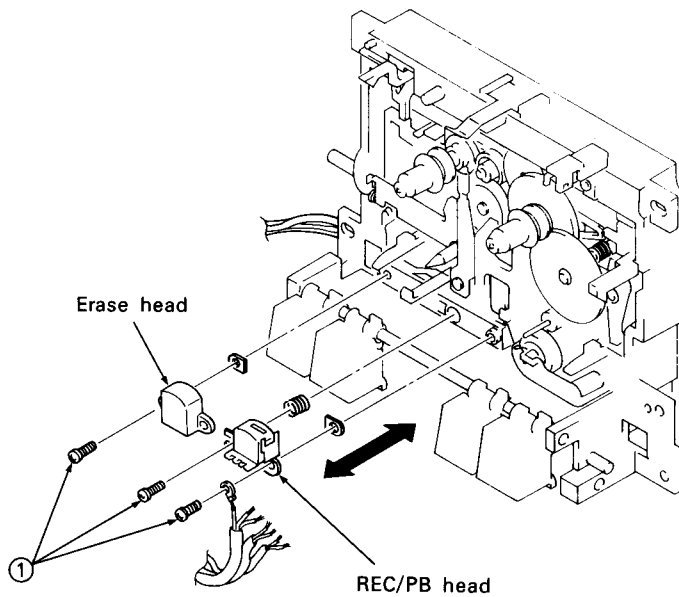
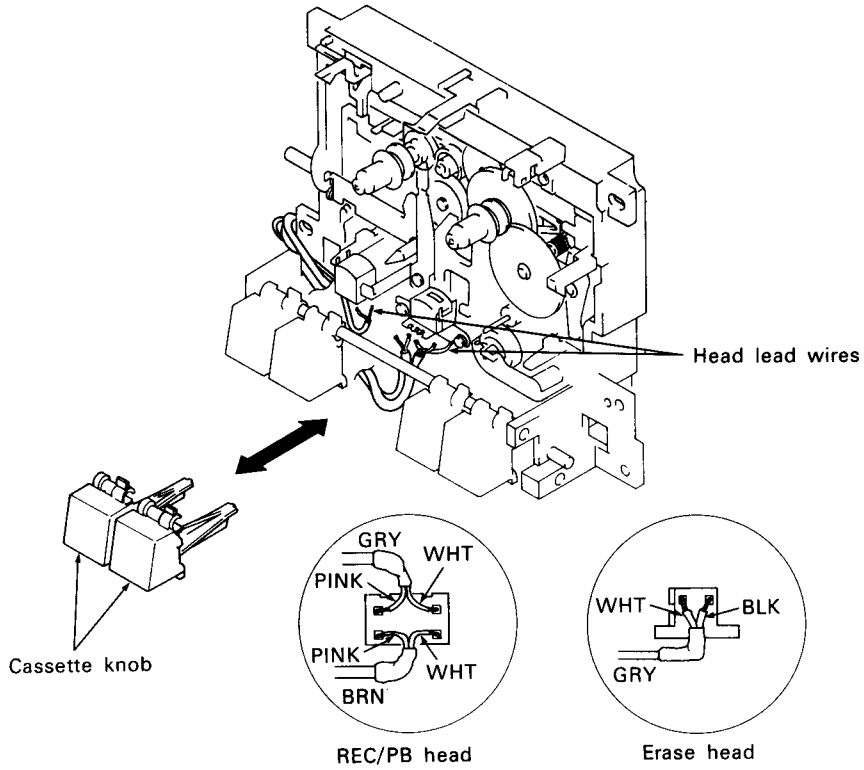

Fig. 3-5

**Replacement of Head**

1. Detach cassette knob.
2. Remove head lead from head.
3. Remove set screw ① of head.
4. Remove former head and install a new one.
5. Solder the head lead while taking precaution not to touch the wirings.
6. Attach cassette knob.
7. Check the running of tape.
8. Perform azimuth adjustment.
9. Perform bias adjustment.



## 4. PARTS LOCATION

**NOTES:**

- The  $\Delta$  mark found on some component parts indicates the importance of the safety factor of the part. Therefore, when replacing, be sure to use parts of identical designation.
- For your Parts Stock Control, the fast moving items are indicated with the marks **★★** and **★**.  
**★★ GENERALLY MOVES FASTER THAN ★**  
 This classification shall be adjusted by each distributor because it depends on model number, temperature, humidity, etc.

### Front Panel View

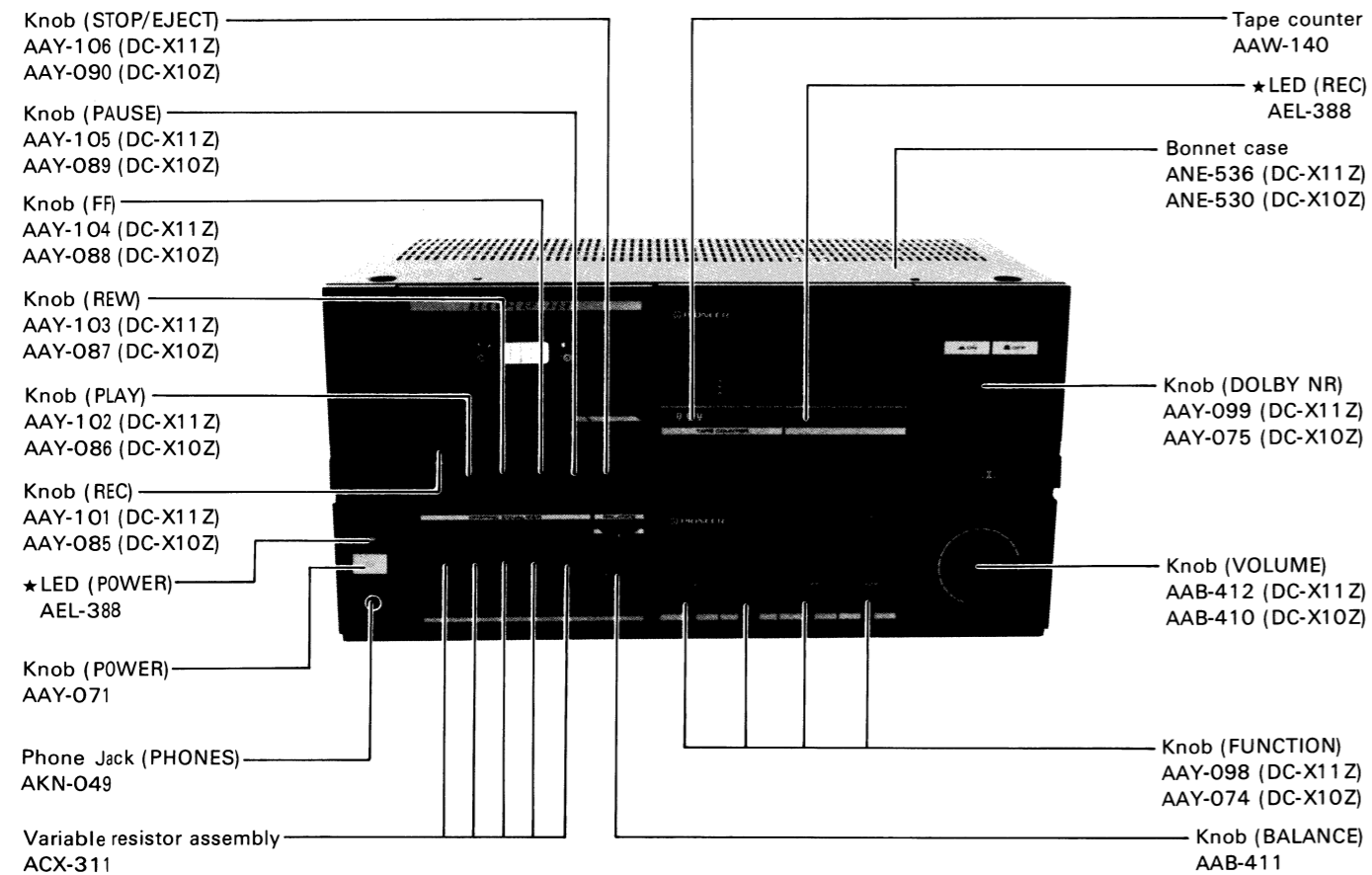

### Rear Panel View

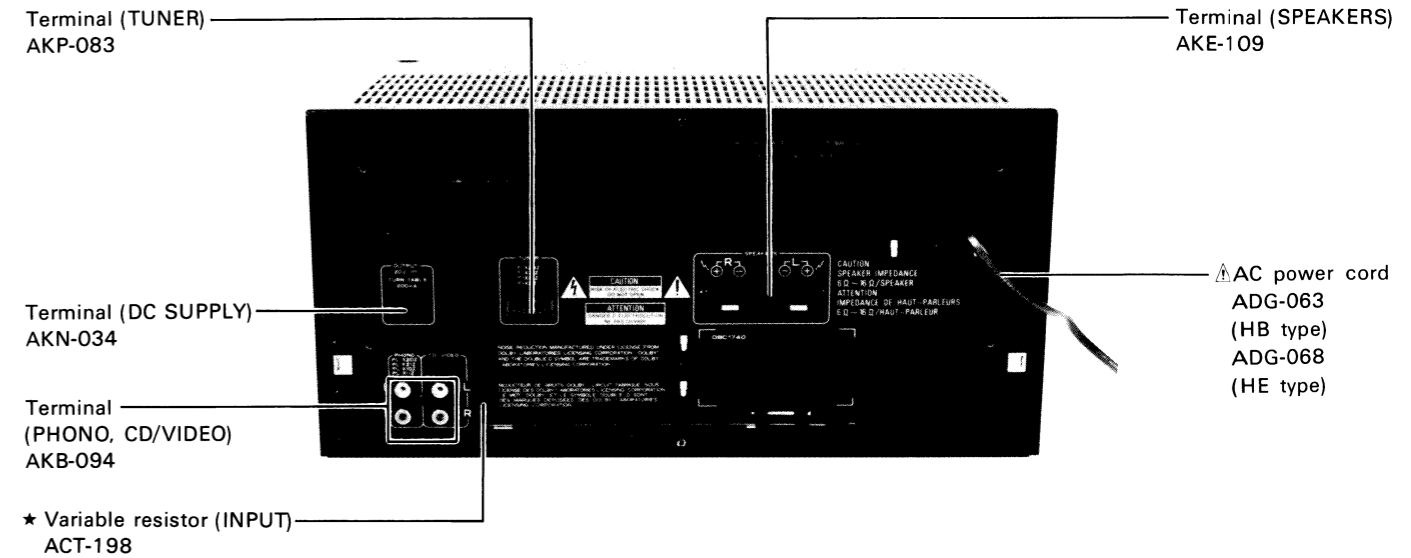

### Top View

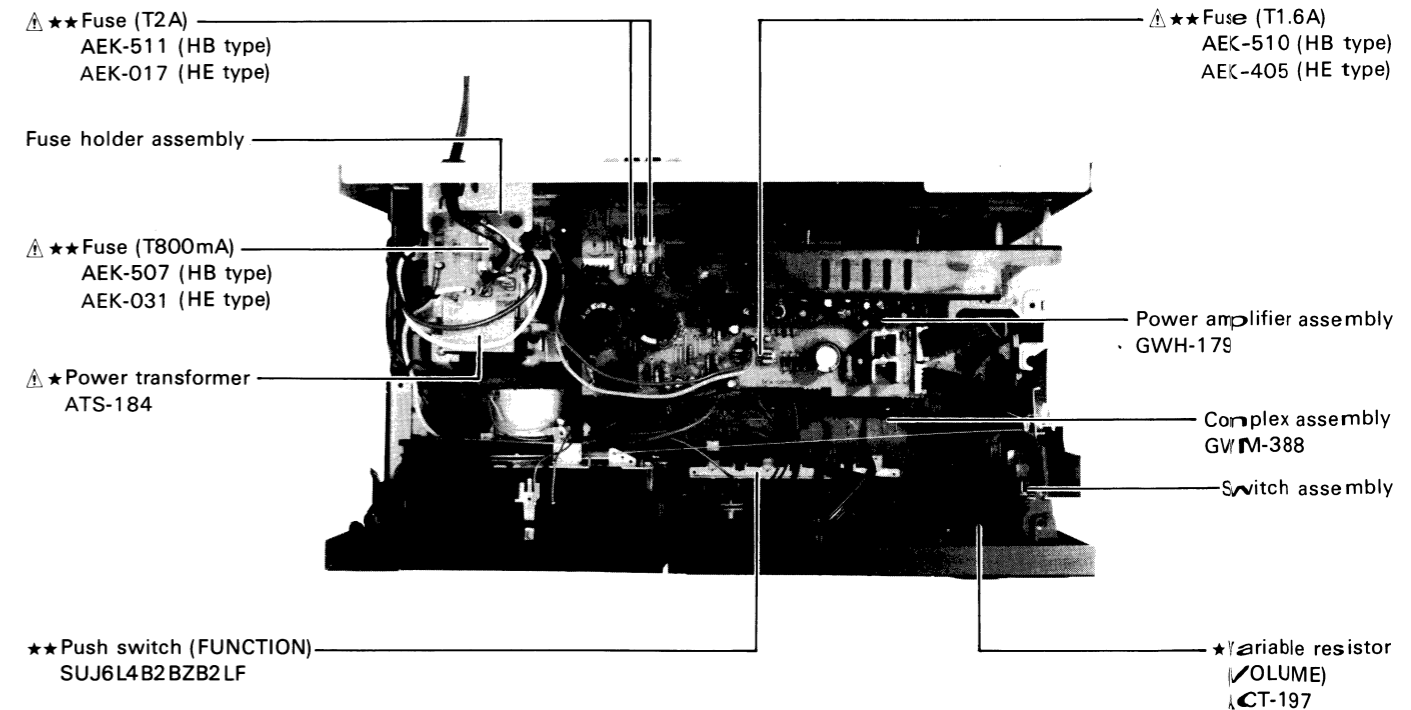

## 5. EXPLODED VIEW

**NOTES:**

- Parts without part number cannot be supplied.
- The  $\Delta$  mark found on some component parts indicates the importance of the safety factor of the part. Therefore, when replacing, be sure to use parts of identical designation.
- For your Parts Stock Control, the fast moving items are indicated with the marks **★★** and **★**.  
**★★ GENERALLY MOVES FASTER THAN ★**  
 This classification shall be adjusted by each distributor because it depends on model number, temperature, humidity, etc.

**Parts List of Exterior**

Mark	No.	Part No.	Description	Mark	No.	Part No.	Description
	1	GWH-179	Power amplifier assembly		15	AAY-099	Knob (DOLBY NR)
	2	GWM-388	Complex assembly			(DC-X11Z)	
★	3	ACX-311	Variable resistor assembly			AAY-075	
$\Delta$ ★	4	ATS-184	Power transformer (220/240V)			(DC-X10Z)	
					16	AAY-101	Knob (REC)
$\Delta$ ★★	5	ASG-541	Push switch (POWER)			(DC-X11Z)	
$\Delta$ ★★	6	AEK-507	Fuse (T800mA)			AAY-085	
		(HB type)				(DC-X10Z)	
		AEK-031			17	AAY-102	Knob (PLAY)
		(HE type)				(DC-X11Z)	
$\Delta$ ★★	7	AEK-510	Fuse (T1.6A)			AAY-086	
		(HB type)				(DC-X10Z)	
		AEK-405			18	AAY-103	Knob (REW)
		(HE type)				(DC-X11Z)	
$\Delta$ ★★	8	AEK-511	Fuse (T2A)			AAY-087	
		(HB type)				(DC-X10Z)	
		AEK-017			19	AAY-104	Knob (FF)
		(HE type)				(DC-X11Z)	
	9	AAW-140	Tape counter			AAY-088	
						(DC-X10Z)	
	10	ANZ-044	Damper assembly		20	AAY-105	Knob (PAUSE)
	11	AAB-411	Knob (BALANCE)			(DC-X11Z)	
	12	AAB-412	Knob (VOLUME)			AAY-089	
		(DC-X11Z)				(DC-X10Z)	
		AAB-410			21	AAY-106	Knob (STOP/EJECT)
		(DC-X10Z)				(DC-X11Z)	
	13	AAY-071	Knob (POWER)			AAY-090	
	14	AAY-098	Knob (FUNCTION)			(DC-X10Z)	
		(DC-X11Z)					
		AAY-074					
		(DC-X10Z)					

Mark	No.	Part No.	Description	Mark	No.	Part No.	Description
	22	ANE-536	Bonnet case		38	BBZ30P080FZK	Screw 3×8
		(DC-X11Z)			39	NK90FUC	Nut
		ANE-530			40	ABA-286	Screw
		(DC-X10Z)			41	VMZ30P060FMC	Screw 3×6
	23	ANM-871	Front panel		42	PBZ20P040FMC	Screw 2×4
		(DC-X11Z)			100		Fuse holder Assembly
		ANM-848			101		Switch assembly
		(DC-X10Z)			102		Headphone jack assembly
★★	24	ANR-964	Door (L)		103		LED assembly (A)
	25	ANR-976	Door panel S		104		LED assembly (B)
	26	ANR-977	REC panel		105		Tape transport unit
	27	ANR-974	POWER panel		106		Chassis
					107		Bottom plate
	28	ANR-984	Deck panel		108		Rear panel
		(DC-X11Z)			109		Heat sink holder
		ANR-978			110		P.C.B holder
		(DC-X10Z)					
	29	ANR-048	Amp panel		111		Damper holder
		(DC-X11Z)			112		REC lever
		ANR-047			113		REC base
		(DC-X10Z)			114		Transformer barrier
	30	AAX-426	Shine paper		115		Switch barrier
	31	ABH-146	REC spring		116		Clamp plate
	32	ABH-147	Coiled spring				
	33	ABH-149	Rod				
	34	ABK-012	Keep plate				
★★	35	AEB-197	Counter belt				
	36	AEC-847	Leg assembly				
$\Delta$	37	ADG-063	AC power cord				
		(HB type)					
		ADG-068					
		(HE type)					

Exterior

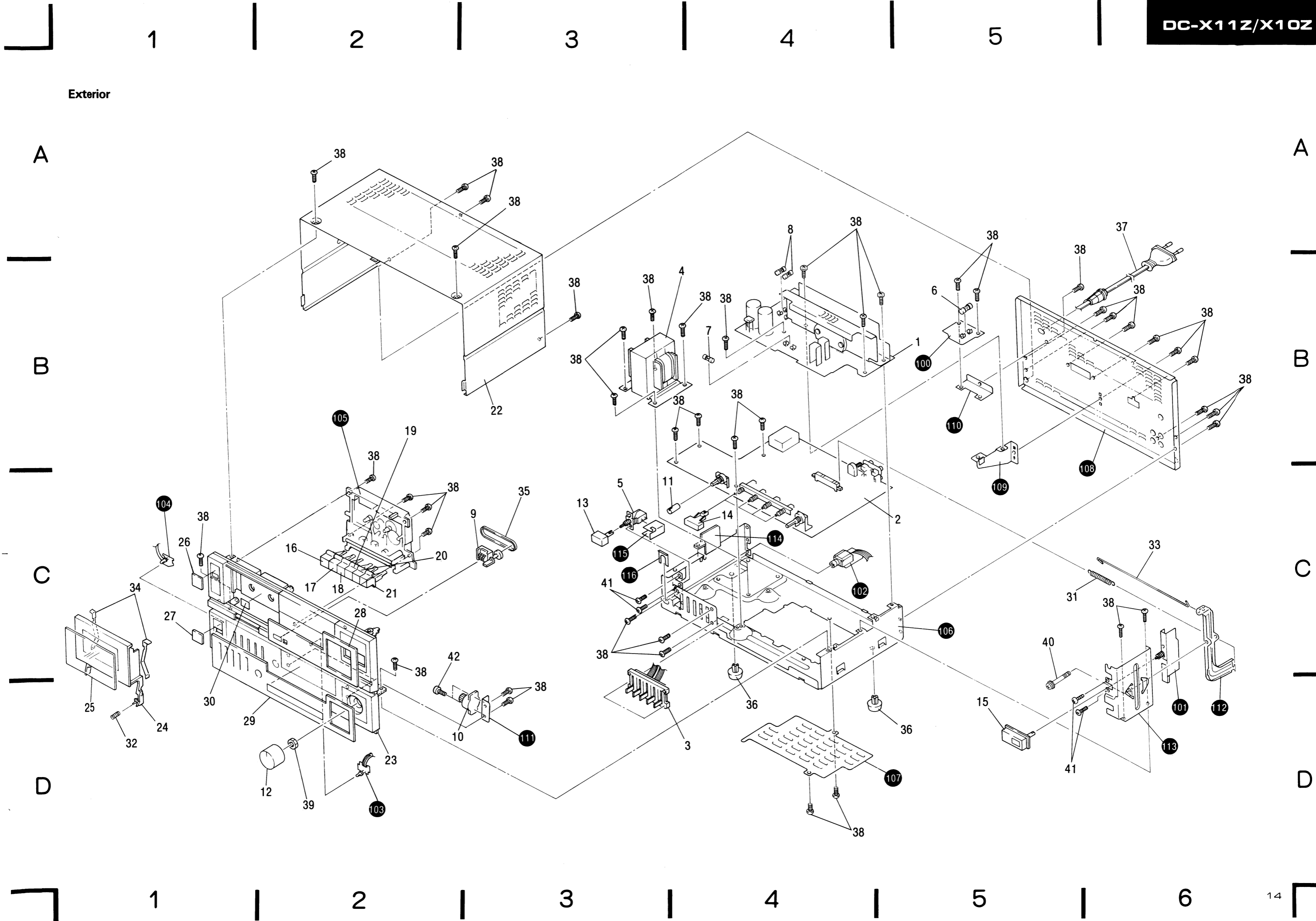

Tape Transport Unit

A

B

C

D

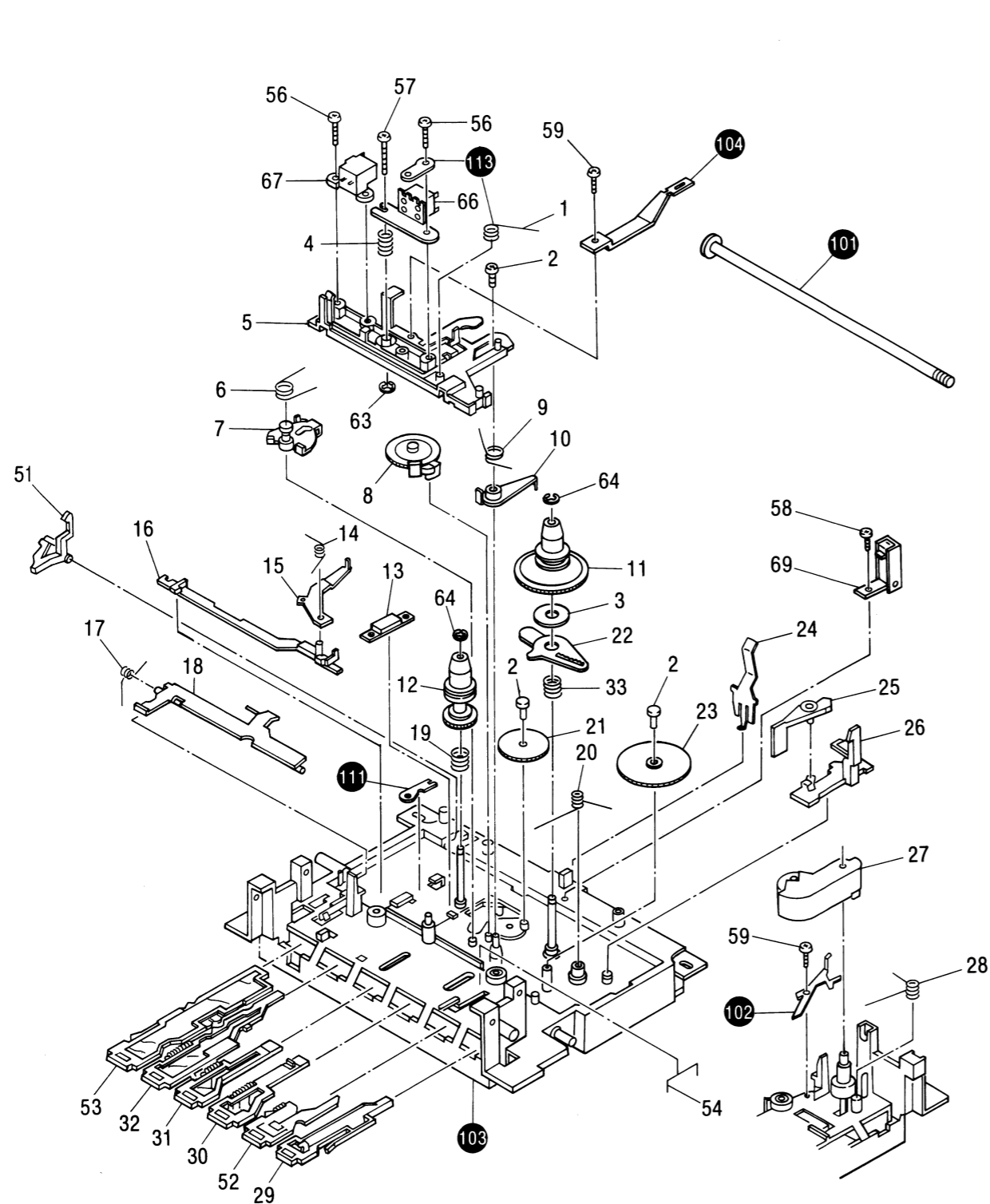

A

B

C

D

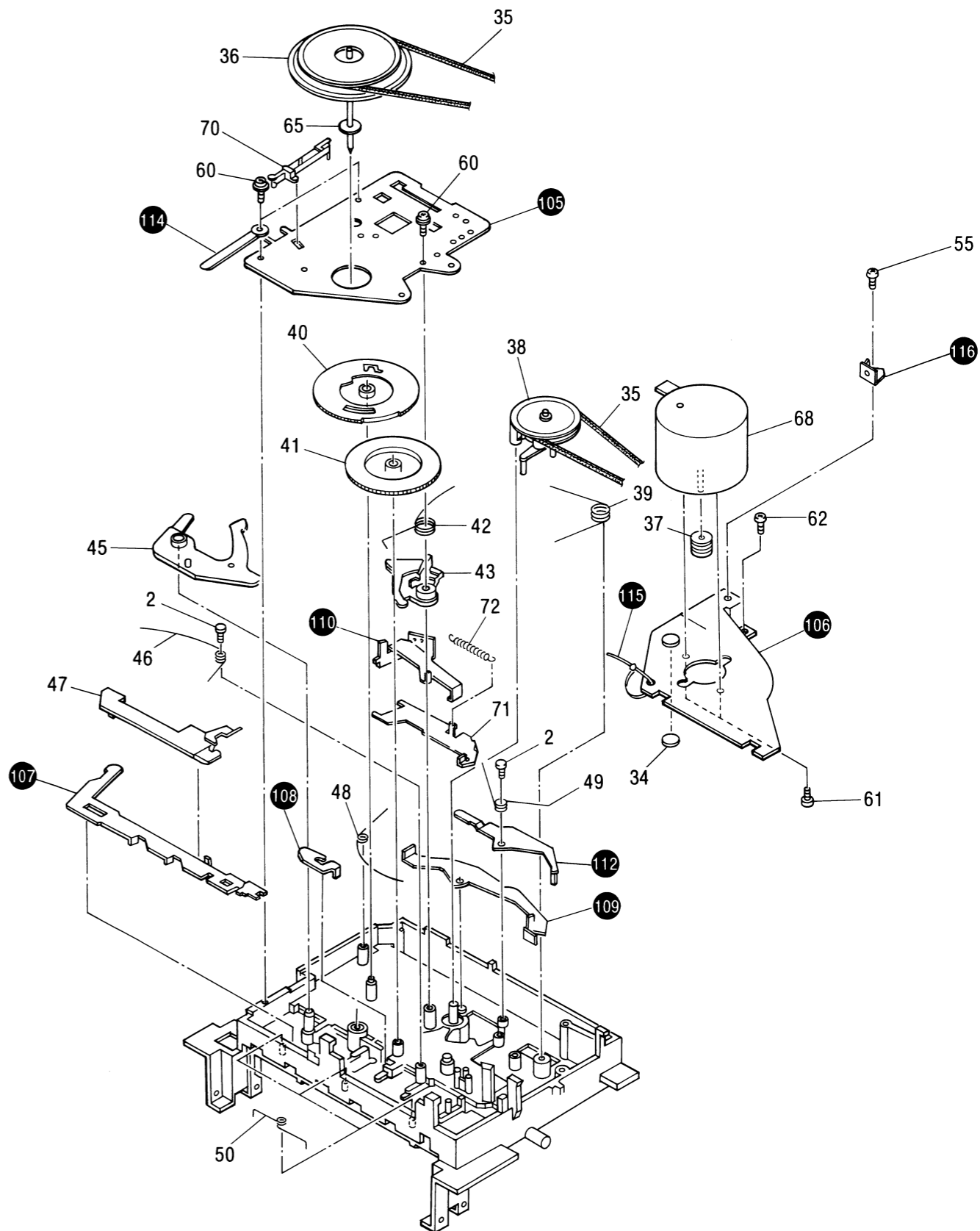

## Parts List of Tape Transport Unit

**NOTES:**

- **Parts without part number cannot be supplied.**
- **The  $\triangle$  mark found on some component parts indicates the importance of the safety factor of the part. Therefore, when replacing, be sure to use parts of identical designation.**
- **For your Parts Stock Control, the fast moving items are indicated with the marks **★★** and **★**.**  
**★★ GENERALLY MOVES FASTER THAN ★**  
**This classification shall be adjusted by each distributor because it depends on model number, temperature, humidity, etc.**

Mark	No.	Part No.	Description	Mark	No.	Part No.	Description
	1	AXV-087	Torsion spring		41	AXS-095	Assist gear B
	2	AXT-007	Bush		42	AXV-098	Torsion spring
	3	AXW-034	Felt		43	AXS-096	P cam lever
	4	AXV-064	Compression spring		44	.....	
	5	AXS-078	Head base		45	AXS-097	CR cam lever
	6	AXV-088	Torsion spring		46	AXV-099	Torsion spring
	7	AXS-079	FR arm		47	AXS-106	FR start lever
★★	8	AXP-037	P idler assembly		48	AXV-100	Torsion spring
	9	AXV-089	Torsion spring		49	AXV-101	Torsion spring
	10	AXS-080	Reset lever		50	AXV-102	Torsion spring
★★	11	AXP-038	T reel assembly		51	AXS-098	Interlock plate
★★	12	AXP-039	S reel assembly		52	AXS-090	Pause lever
	13	AXS-081	FR release lever		53	AXS-100	REC lever
	14	AXV-090	Torsion spring		54	AXV-103	Lock pin
	15	AXS-082	P release lever		55	BDZ26P050FMC	Screw 2.6×5
	16	AXS-083	PL plate		56	BTZ20P080FMC	Screw 2×8
	17	AXV-091	Torsion spring		57	BMZ20P100FMC	Screw 2×10
	18	AXS-099	FR plate		58	PTZ26P060FMC	Screw 2.6×6
	19	AXV-092	S brake spring		59	BTZ20P050FMC	Screw 2×5
	20	AXV-093	Torsion spring		60	BTZ26P060FMC	Screw 2.6×6
	21	AXS-084	F idler gear		61	PMA26P040FMC	Screw 2.6×4
	22	AXS-085	Sensor cam		62	PDZ26P040FMC	Screw 2.6×4
	23	AXS-086	AS gear		63	NA20FMC	Nut M2
	24	AXV-094	Cassette holder		64	WA16D040D020	Washer 1.6×4×0.2
	25	AXS-087	Eject cam		65	WA21D040D030	Washer 2.1×4×0.3
	26	AXS-088	Latch lever	★★	66	AXN-031	REC/PB head
★★	27	AXP-040	Pinch arm assembly	★	67	AXN-032	Erase head
	28	AXV-095	Torsion spring	★★	68	AXN-023	Motor
	29	AXS-089	SE lever	★★	69	AXN-024	Spring switch (S12, METAL)
	30	AXS-091	FF lever				
	31	AXS-092	REW lever	★★	70	AXN-025	Spring switch (S11, MUTE)
	32	AXS-093	PL lever B		71	AXS-102	REC link lever
	33	AXV-096	Torsion spring		72	AXV-106	Tension spring
	34	AXW-035	Thrust receptacle		101		Button shaft
★★	35	AXW-036	Belt		102		Grounding lug
	36	AXP-041	Flywheel assembly		103		Chassis
	37	AXS-101	Motor pulley		104		REV plate
★★	38	AXP-042	FR idler arm assembly		105		Gear holder
	39	AXV-104	Torsion spring				
	40	AXS-094	Assist gear A				

# DC-X11Z/X10Z

<u>Mark</u>	<u>No.</u>	<u>Part No.</u>	<u>Description</u>
	106		Motor holder
	107		FR S lever
	108		Protector
	109		PL start lever
	110		RS W lever
	111		REC protector
	112		REC change plate
	113		Lug
	114		Cord fixer
	115		Wire tie
	116		Lug terminal



## 6. ELECTRICAL PARTS LIST

### NOTES:

- When ordering resistors, first convert resistance values into code form as shown in the following examples.

Ex. 1 When there are 2 effective digits (any digit apart from 0), such as 560 ohm and 47k ohm (tolerance is shown by J=5%, and K=10%).

560Ω 56 × 10<sup>1</sup> 561 ..... RD½PS  $\square$  $\square$  $\square$  J  
 47kΩ 47 × 10<sup>3</sup> 473 ..... RD½PS  $\square$  $\square$  $\square$  J  
 0.5Ω 0R5 ..... RN2H  $\square$  $\square$  $\square$  K  
 1Ω 010 ..... RS1P  $\square$  $\square$  $\square$  K

Ex. 2 When there are 3 effective digits (such as in high precision metal film resistors).

5.62kΩ 562 × 10<sup>1</sup> 5621 .... RN½SR  $\square$  $\square$  $\square$  $\square$  F

- The  $\Delta$  mark found on some component parts indicates the importance of the safety factor of the part. Therefore, when replacing, be sure to use parts of identical designation.

- For your Parts Stock Control, the fast moving items are indicated with the marks **★** and **★**.

**★★ GENERALLY MOVES FASTER THAN ★**

This classification shall be adjusted by each distributor because it depends on model number, temperature, humidity, etc.

### Miscellaneous Parts

#### P.C. BOARD ASSEMBLIES

Mark	Symbol & Description	Part No.
	Power amplifier assembly	GWH-179
	Complex assembly	GWM-388
	Switch Assembly	Non supply
	Headphone jack assembly	Non supply
	Fuse holder assembly	Non supply
	LED assembly (B)	Non supply
	LED assembly (A)	Non supply

#### SWITCH

Mark	Symbol & Description	Part No.
$\Delta$ ★★	S1 Push switch (POWER)	ASG-541

#### TRANSFORMER

Mark	Symbol & Description	Part No.
$\Delta$ ★	T1 Power transformer (220/240V)	ATS-184

#### RESISTOR

Mark	Symbol & Description	Part No.
★	VR1 Variable resistor assembly (GRAPHIC EQUALIZER)	ACX-311

#### FUSES

Mark	Symbol & Description	Part No.
$\Delta$ ★★	FU4, FU5 Fuse (T2A)	AEK-017(HE) AEK-511(HB)
$\Delta$ ★★	FU1 Fuse (T800mA)	AEK-031(HE) AEK-507(HB)
$\Delta$ ★★	FU3 Fuse (T1.6A)	AEK-405(HE) AEK-510(HB)

#### OTHERS

Mark	Symbol & Description	Part No.
$\Delta$	AC Power cord (for HE type) (for HB type)	ADG-068 ADG-063
$\Delta$	C1 Ceramic capacitor	ACG-502

### Complex Assembly (GWM-388)

#### SEMICONDUCTORS

Mark	Symbol & Description	Part No.
★★	IC701, IC702	BA3812L
★★	IC401	HA12045
★★	IC501	M5218L
★★	IC601	M5218P
★★	IC301	M5220L
★★	Q842	DTA143ES (RN2201)
★★	Q810, Q841	DTC124ES (RN1203)
★★	Q801	2SA933S (2SA1048)
★★	Q303, Q304, Q401—Q406, Q408, Q409, Q501, Q502, Q505, Q506, Q846	2SC1740S (2SC2458)
★★	Q843	2SC2603 (2SC2458)
★★	Q844, Q845	2SD438
★★	Q301, Q302	2SC2878
★	D833	RD5.6EB (HZ5.6EB)
★	D401, D402, D808, D822, D840—D843	1SS131

#### SWITCHES

Mark	Symbol & Description	Part No.
★★	S401 Slide switch (REC/PB)	ASH-105
★★	S701 Push switch (FUNCTION)	SUJ6L4B2B2B2LF

### COILS AND TRANSFORMERS

Mark	Symbol & Description	Part No.
	F401, F402 MPX filter	ATF-158
	L801 Inductor	ATH-094
	L501, L502 Inductor	ATH-117
	L401, L402 Trap coil	ATM-031
	L503, L504 Trap coil	ATM-032
	T801 Oscillator transformer	ATX-036

### CAPACITORS

Mark	Symbol & Description	Part No.
	C804 Polypropylene (1500p/630V)	ACE-133
	C723, C724 Ceramic (330p/50V)	ACG-028
	C417, C418 Electrolytic (0.27/50V)	ACH-387
	C419, C420 Electrolytic (0.82/50V)	ACH-388
	C305, C306, C605—C608	CCCSL101J50 (CCDSL101J50)
	C802, C803	CCCSL101K500 (CCDSL101K500)
	C403, C404, C429, C430	CCCSL470J50 (CCDSL470J50)
	C709, C710	CEASR15M50
	C801	CEASR47M50
	C705, C706	CEASR68M50
	C303, C304, C423, C424, C517, C518, C615, C616, C815	CEASO10M50
	C311, C312, C407, C408, C425, C426, C501, C502, C519, C520, C701, C702, C727, C728, C814	CEAS100M25
	C453, C725, C726	CEAS101M16
	C401, C402, C405, C406, C427, C428, C452, C603, C604	CEAS2R2M50
	C451, C454	CEAS221M16
	C307, C308, C505, C506	CEAS330M16
	C415, C416	CEAS4R7M50
	C609, C610	CEAS470M10
	C351, C352, C651, C652, C751, C809, C810	CEAS470M16
	C715, C716	CKCYB182K50 (CKDYB182K50)
	C719, C720	CKCYB391K50 (CKDYB391K50)
	C711, C712	CKCYB392K50 (CKDYB392K50)
	C301, C302	CKCYB471K50 (CKDYB471K50)
	C521—C524	CKCYB681K50 (CKDYB681K50)
	C721, C722	CKCYB682K50 (CKDYB682K50)

Mark	Symbol & Description	Part No.
	C717, C718	CKCYX153M25 (CKDYX153M25)
	C707, C708	CKCYX183M25 (CKDYX183M25)
	C703, C704	CKCYX393M25 (CKDYX393M25)
	C713, C714	CKCYX683M25 (CKDYX683M25)
	C806, C808	CQMA153J50
	C503, C504	CQMA182J50
	C421, C422	CQMA183J50
	C313, C314, C507, C508, C805, C807	CQMA223J50
	C611, C612	CQMA242J50
	C411, C412	CQMA333J50
	C511, C512	CQMA393J50
	C413, C414	CQMA472J50
	C309, C310	CQMA562J50
	C613, C614	CQMA822J50

### RESISTORS

NOTE: When ordering resistors, convert the resistance value into code form, and then rewrite the part no. as before.

Mark	Symbol & Description	Part No.
★	VR701 Variable (BALANCE)	ACT-057
★	VR702 Variable (VOLUME)	ACT-197
★	VR601 Variable (INPUT)	ACT-198
★	VR841, VR842 Semi-fixed 220k	VRTB6VS224
★	VR301, VR302, VR501, VR502, Semi-fixed 22k	VRTB6VS223
	R842	RD1/2PM271J
	R319, R320	RD1/4PM105J
	Other resistors	RD1/8PM□□□J

### OTHERS

Mark	Symbol & Description	Part No.
	Terminal (PHONO, CD/VIDEO)	AKB-094

### Switch Assembly

#### SWITCHES

Mark	Symbol & Description	Part No.
★★	S902 Push switch (DOLBY NR)	SUJL2SF

### RESISTORS

Mark	Symbol & Description	Part No.
	R821	RD1/8PM472J
	R822	RD1/8PM622J

Part No.

CKCYX153M25  
(CKDYX153M25)  
CKCYX183M25  
(CKDYX183M25)  
CKCYX393M25  
(CKDYX393M25)

CKCYX683M25  
(CKDYX683M25)  
CQMA153J50  
CQMA182J50  
CQMA183J50

CQMA223J50

CQMA242J50  
CQMA333J50  
CQMA393J50

CQMA472J50  
CQMA562J50  
CQMA822J50

Convert the resistance value  
into code form, and then rewrite the part no. as before.

Part No.

E) ACT-057  
) ACT-197  
ACT-198  
VRTB6VS224  
  
VRTB6VS223  
  
RD1/2PM271J  
RD1/4PM105J  
RD1/8PM□□□J

Part No.

EO) AKB-094

Part No.

NR) SUJL2SF

Part No.

RD1/8PM472J  
RD1/8PM622J

**Headphone Jack Assembly****RESISTORS**

*NOTE: When ordering resistors, convert the resistance value into code form, and then rewrite the part no. as before.*

Mark	Symbol & Description	Part No.
	R829, R830	RD1/2PM331J

**OTHERS**

Mark	Symbol & Description	Part No.
	Phone jack (PHONES)	AKN-049

**LED Assembly (A)****SEMICONDUCTOR**

Mark	Symbol & Description	Part No.
*	D828 LED (REC)	AEL-388

**LED Assembly (B)****SEMICONDUCTOR**

Mark	Symbol & Description	Part No.
*	D827 LED (POWER)	AEL-388

**Power Amplifier Assembly (GWH-179)****SEMICONDUCTORS**

Mark	Symbol & Description	Part No.
△ **	IC101	STK4141-2S
**	IC102, IC103	μPC78M12H
**	Q104	2SB834
**	Q101—Q103	2SC1740S (2SC2603)
*	D101	KZL150
△ *	D106	3D4B41
*	D105	RD13EB (HZ13EB)
△ *	D103, D104, D107—D110	S5566 (11E2)
*	D102	1S2471

**RELAY**

Mark	Symbol & Description	Part No.
* *	RY101 Relay	ASR-111

**COIL**

Mark	Symbol & Description	Part No.
	L103, L104 AF choke coil	ATH-053

**CAPACITORS**

Mark	Symbol & Description	Part No.
	C131, C132 Ceramic (0.01/AC150V)	ACG-019
	C128, C129 Electrolytic (3300/42V)	ACH-249
	C105, C106	CCCSL470J50 (CCDSL470J50)
	C101, C102	CCCSL101J50 (CCDSL101J50)
	C119	CEASR47M100
	C113, C115, C116	CEAS100M50
	C107, C108	CEAS101M10
	C109, C110, C118	CEAS101M25
	C114	CEAS101M50
	C103, C104	CEAS2R2M50
	C126, C127	CEAS330M25
	C130	CEAS332M25
	C111, C112, C124, C125	CEAS470M25
	C133	CEAS470M50
	C117	CEAS471M6
	C120, C121	CKCYF473Z50 (CKDYF473Z50)

**RESISTORS**

*NOTE: When ordering resistors, convert the resistance value into code form, and then rewrite the part no. as before.*

Mark	Symbol & Description	Part No.
△	R129, R130	RD1/2PMF□□□J
	R133, R137, R138	RD1/2PM□□□J
△	R125, R126, R141, R142, R134, R118, R119, R120, R136	RD1/4PMF□□□J
	R124	RS1LMF681J
	R131	RS2LMF221J
	R132	RS2LMF271J
	R139	RS2LMF4R7J
	Other resistors	RD1/4PM□□□J

**OTHERS**

Mark	Symbol & Description	Part No.
	Terminal (SPEAKERS)	AKE-109
	Terminal (DC SUPPLY)	AKN-034
	Terminal (TO TUNER)	AKP-083
	Screw	ABA-271
	Heat proof rivet	AEC-940
	Screw 3×6	PBZ30P060FMC

**Fuse Holder Assembly****RESISTOR**

Mark	Symbol & Description	Part No.
△	R140 Carbon composition (2.2M 1/2W)	ACN-209

# 7. P.C. BOARDS CONNECTION DIAGRAM

A

COMPLEX ASSEMBLY (GWM-388)

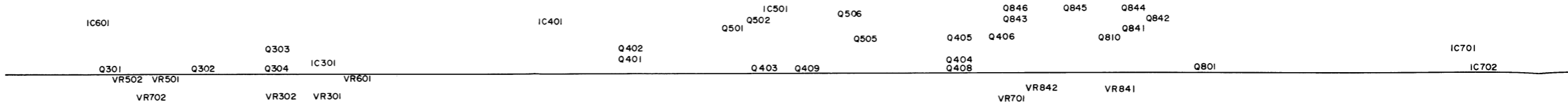

B

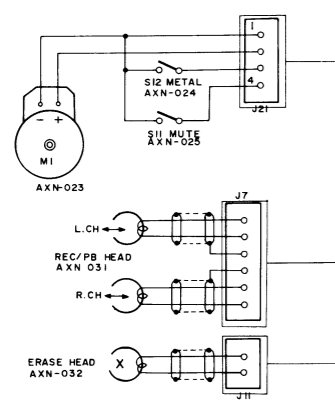

C

D

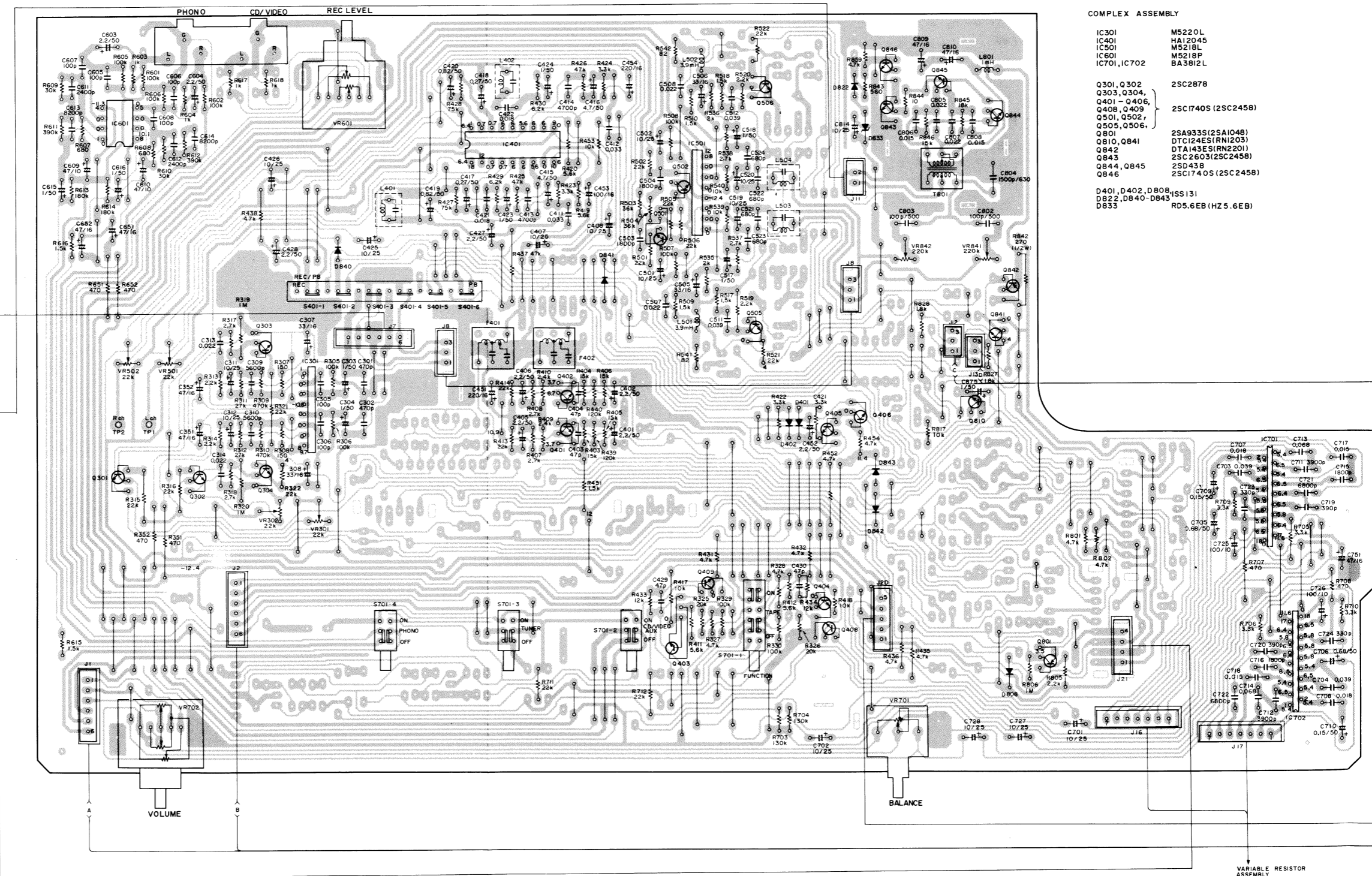

- COMPLEX ASSEMBLY
- IC301 M5220L
  - IC401 HA12045
  - IC501 M5218L
  - IC601 M5218P
  - IC701, IC702 BA3812L
- Q301, Q302 2SC2878
  - Q303, Q304, Q401-Q406, Q408, Q409, Q501, Q502, Q505, Q506, Q810, Q841 2SC1740S (2SC2458)
  - Q842, Q843, Q844, Q845, Q846 2SA933S(2SA1048) DTA143ES(RN203) 2SC2603(2SC2458) 2SD438 2SC1740S (2SC2458)
  - D401, D402, D808, D833 1SS131 RD5.6EB (HZ 5.6EB)

VARIABLE RESISTOR ASSEMBLY

POWER AMP ASSEMBLY (GWH-179)

IC101  
IC102  
IC103

Q102 Q101  
Q103

Q104

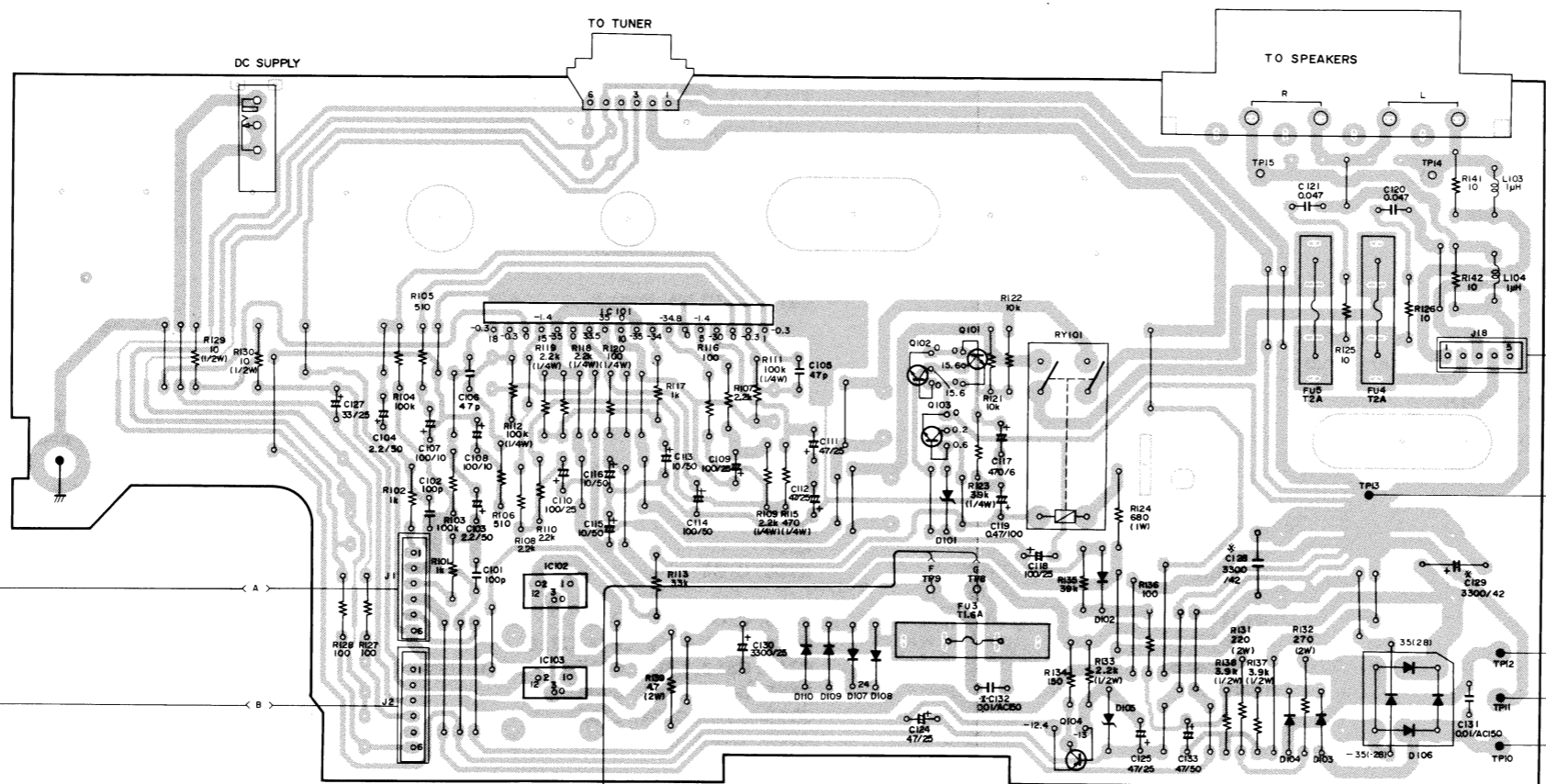

POWER AMP ASSEMBLY

IC101	STK4141-2S
IC102, IC103	μPC 78M12H
Q101-Q103	2SC1740S (2SC2603)
Q104	2SB834
D101	KZL150
D102	IS2471
D103, D104,	S5566 (HE2)
D105	RD13EB (HZ13EB)
D106	3D4B41

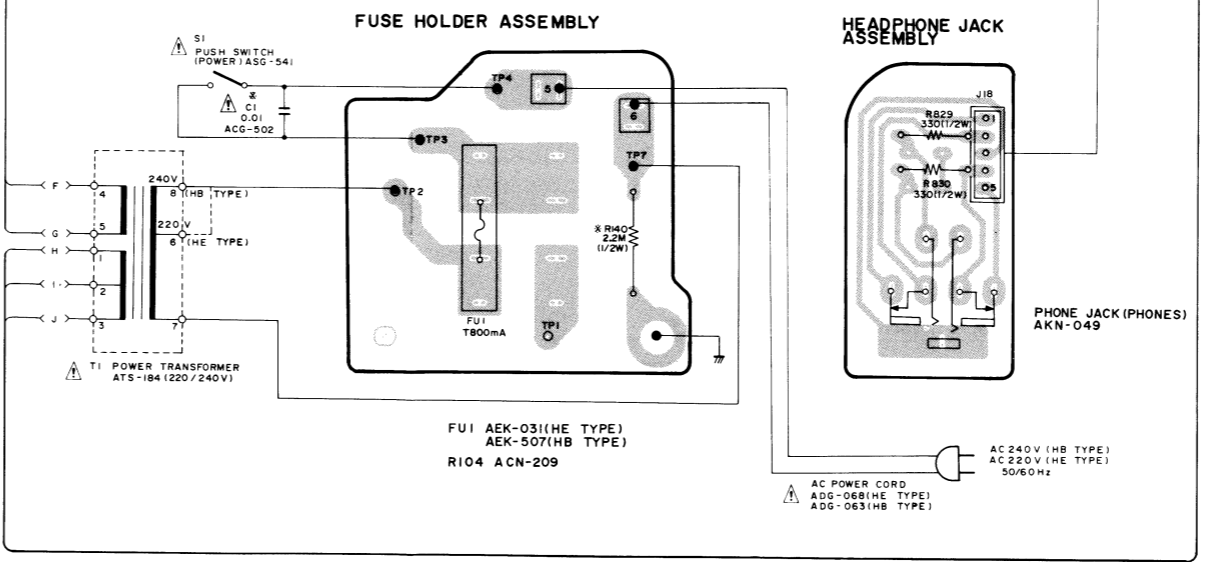
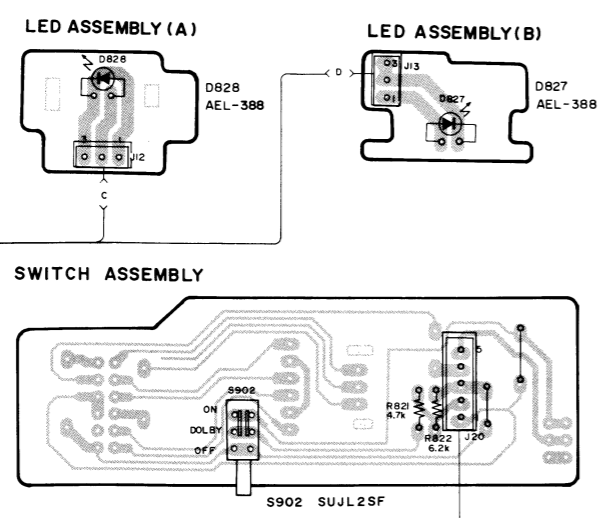

IC701  
IC702

SC2458)

(1048)  
(1203)  
(12201)  
C2458)

SC2458)

5.6EB)

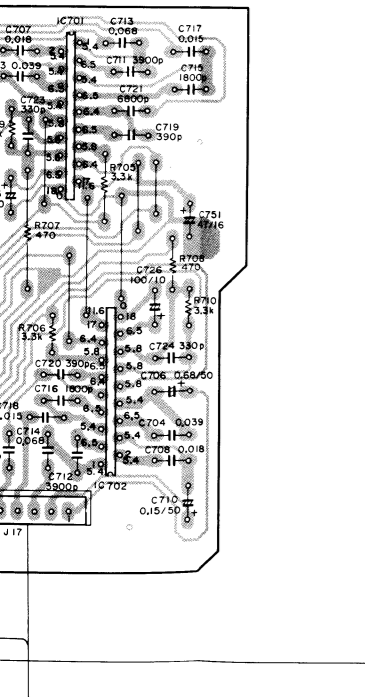

VARIABLE RESISTOR ASSEMBLY

A

B

C

D

# 8. SCHEMATIC DIAGRAM

COMPLEX ASSEMBLY GWM-388

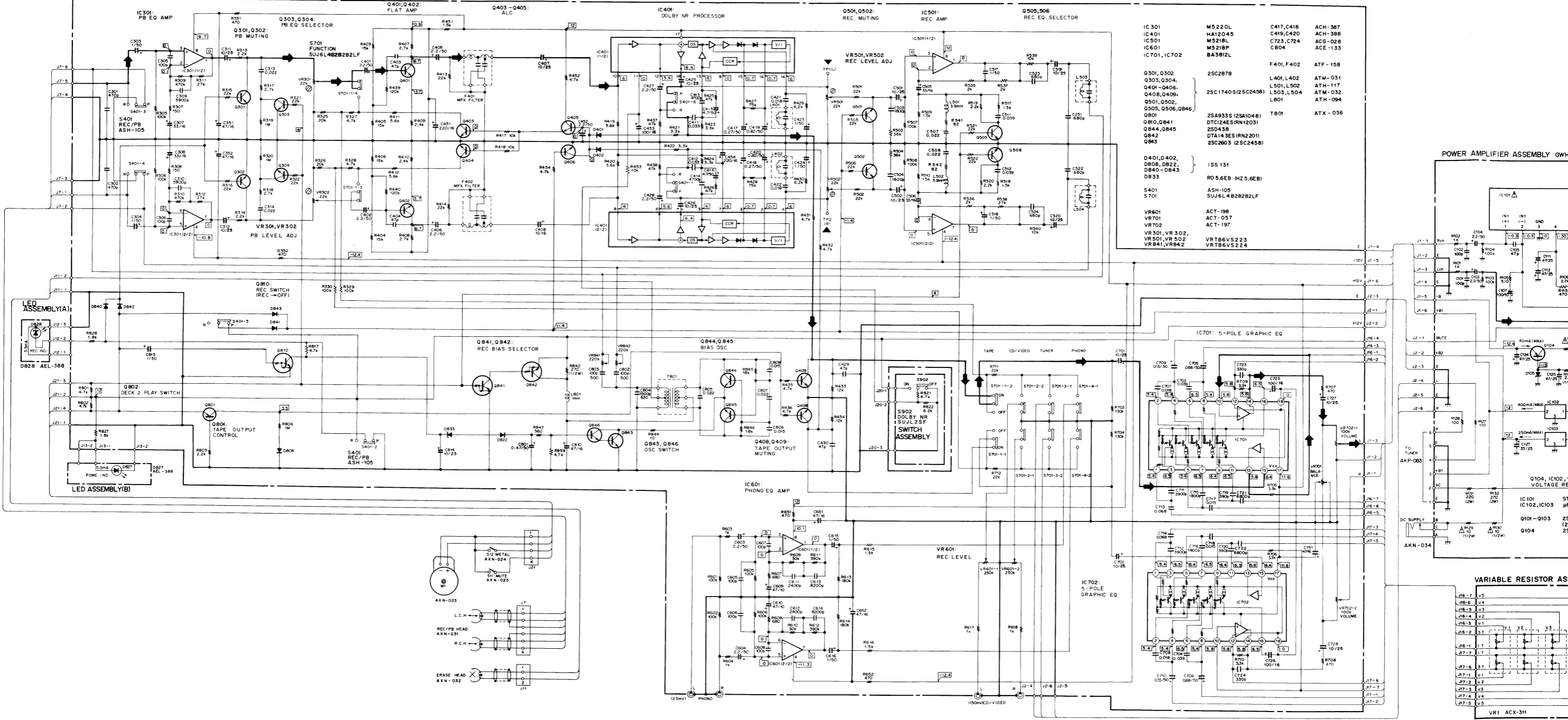

- |  |                            |            |         |
|--|----------------------------|------------|---------|
| IC301                                      | M5220L                     | C417, C418 | ACH-387 |
| IC401                                      | HA12045                    | C419, C420 | ACH-388 |
| IC501                                      | M5218L                     | C723, C724 | ACQ-028 |
| IC601                                      | M5218P                     | C804       | ACE-133 |
| IC701, IC702                               | BA3812L                    |            |         |
| Q301, Q302                                 | 25C2878                    | F401, F402 | ATF-158 |
| Q401-Q406                                  | L401, L402                 |            | ATH-031 |
| Q408, Q409                                 | 25C1740S(25C2458)          | L501, L502 | ATH-117 |
| Q501, Q502                                 |                            | L503, L504 | ATH-032 |
| Q505, Q506, Q846                           |                            | L801       | ATH-094 |
| Q801                                       | 25A9335 (25A1048)          | T801       | ATX-036 |
| Q810, Q841                                 | DT024ES(RN1203)            |            |         |
| Q844, Q845                                 | 25D438                     |            |         |
| Q842                                       | DTA143ES(RN2201)           |            |         |
| Q843                                       | 25C2603 (25C2458)          |            |         |
| D401, D402, D808, D822, D840-D843          | ISS 131                    |            |         |
| D833                                       | RD 5.6EB (HZ 5.6EB)        |            |         |
| S401                                       | ASH-105                    |            |         |
| S701                                       | SUJ6L482B2BLF              |            |         |
| VR601                                      | ACT-198                    |            |         |
| VR701                                      | ACT-057                    |            |         |
| VR702                                      | ACT-197                    |            |         |
| VR501, VR 302, VR501, VR 502, VR841, VR842 | VRT66V5 223<br>VRT66V5 224 |            |         |

POWER AMPLIFIER ASSEMBLY GWM-388

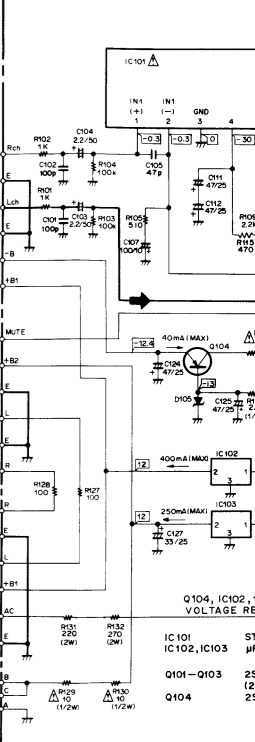

VARIABLE RESISTOR ASS

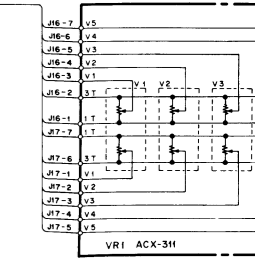

1

2

3

4

5

6

7

6

7

8

9

External Appearance of Transistors and ICs

ACH-307  
ACH-388  
ACG-028  
ACE-133  
ATF-158  
ATM-031  
ATM-117  
ATM-032  
ATH-094  
ATX-036

- RESISTORS:**  
Indicated in  $\Omega$ , 1/4W and 1/8W,  $\pm 5\%$  tolerance unless otherwise noted k: k $\Omega$ , M: M $\Omega$ , (F):  $\pm 1\%$ , (G):  $\pm 2\%$ , (K):  $\pm 10\%$ , (M):  $\pm 20\%$  tolerance
- CAPACITORS:**  
Indicated in capacity ( $\mu$ F)/voltage (V) unless otherwise noted p: pF. Indication without voltage is 50V except electrolytic capacitor.
- VOLTAGE, CURRENT:**  
V: Signal voltage at 2.5W + 2.5W, 8 $\Omega$  output (1 kHz)  
DC: DC voltage (V) at no input signal Value in ( ) is DC voltage at rated power.  
mA: DC current at no input signal
- OTHERS:**  
: Signal route.  
: Adjusting point.  
The  $\Delta$  mark found on some component parts indicates the importance of the safety factor of the part. Therefore, when replacing, be sure to use parts of identical designation.  
\* marked capacitors and resistors have parts numbers.

HEADPHONE JACK ASSEMBLY

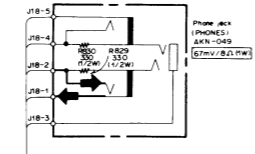

POWER AMPLIFIER ASSEMBLY GWH-179

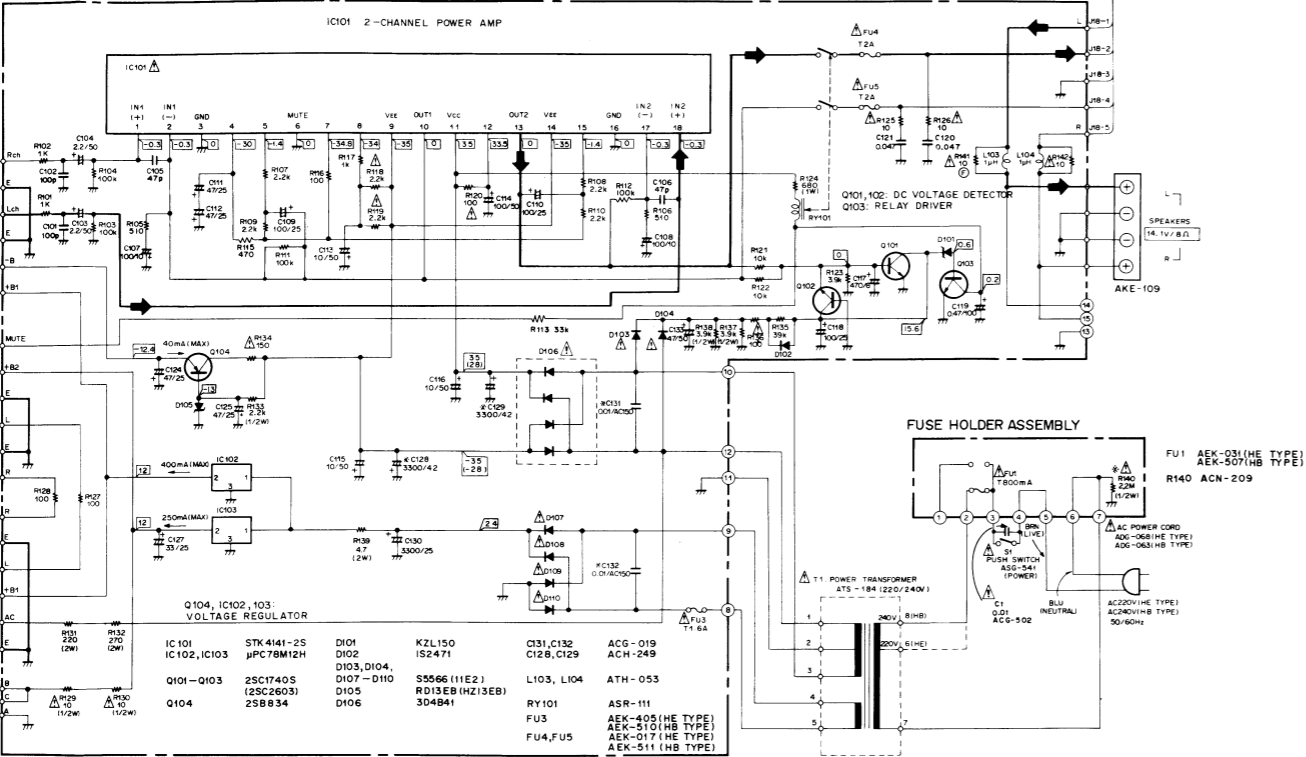

FUSE HOLDER ASSEMBLY

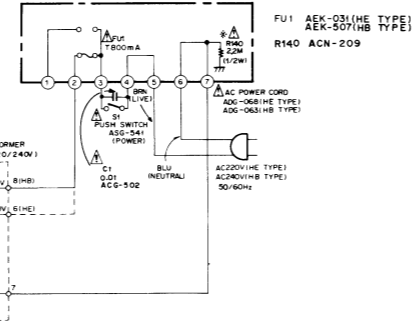

VARIABLE RESISTOR ASSEMBLY

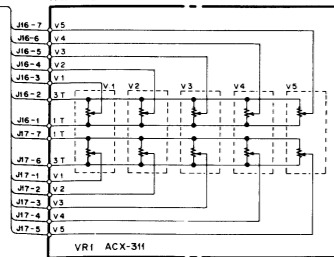

- SWITCHES:**
- OUTSIDE OF P.C. BOARDS**
- S1: POWER** ON-OFF
- TAPE TRANSPORT UNIT**
- S11: MUTE** ON-OFF
- S12: TAPE TYPE METAL** ON-OFF
- COMPLEX ASSEMBLY**
- S401: REC./PB SELECTOR** REC-PLAY
- S701: FUNCTION** ON-OFF
- S701-1: TAPE** ON-OFF
- S701-2: CD/VIDEO** ON-OFF
- S701-3: TUNER** ON-OFF
- S701-4: PHONO** ON-OFF
- SWITCH ASSEMBLY**
- S802: DOLBY NR** ON-OFF

THE UNDERLINED INDICATES THE SWITCH POSITION

This is the basic schematic diagram, but the actual circuit may vary due to improvements in design.

A

BA3812L

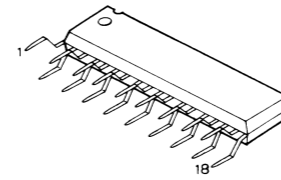

2SA933S  
2SC1740S

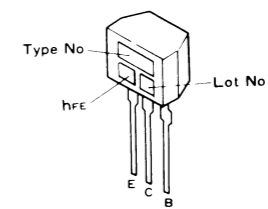

DTA143ES  
DTC124ES

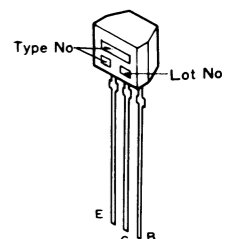

B

HA12045

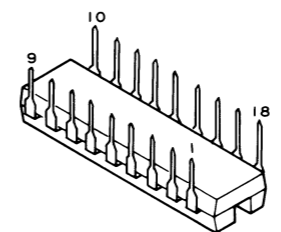

2SA1048  
2SC2458

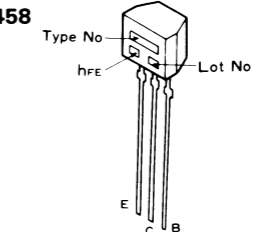

RN1203  
RN2201

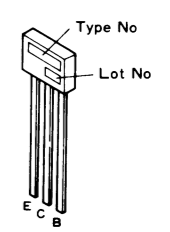

C

M5218L  
M5220L

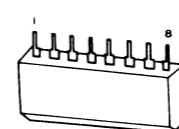

2SB834

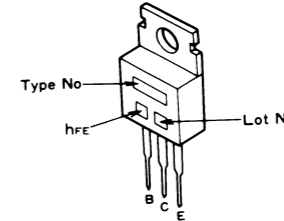

M5218P

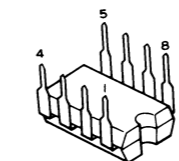

2SC2603

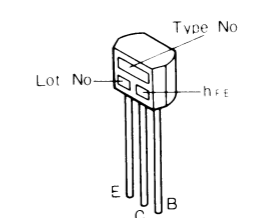

STK4141-2S

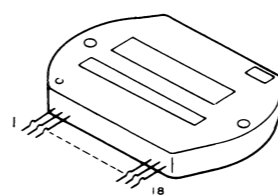

2SC2878

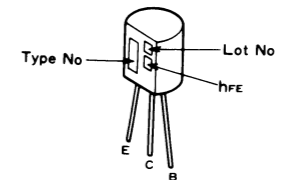

D

$\mu$ PC78M12H

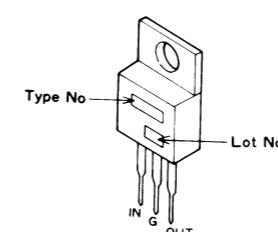

2SD438

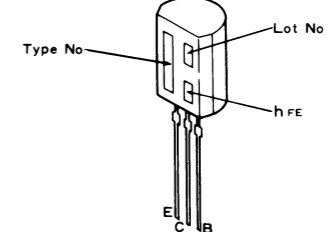

6

7

8

9

## 9. BLOCK DIAGRAM

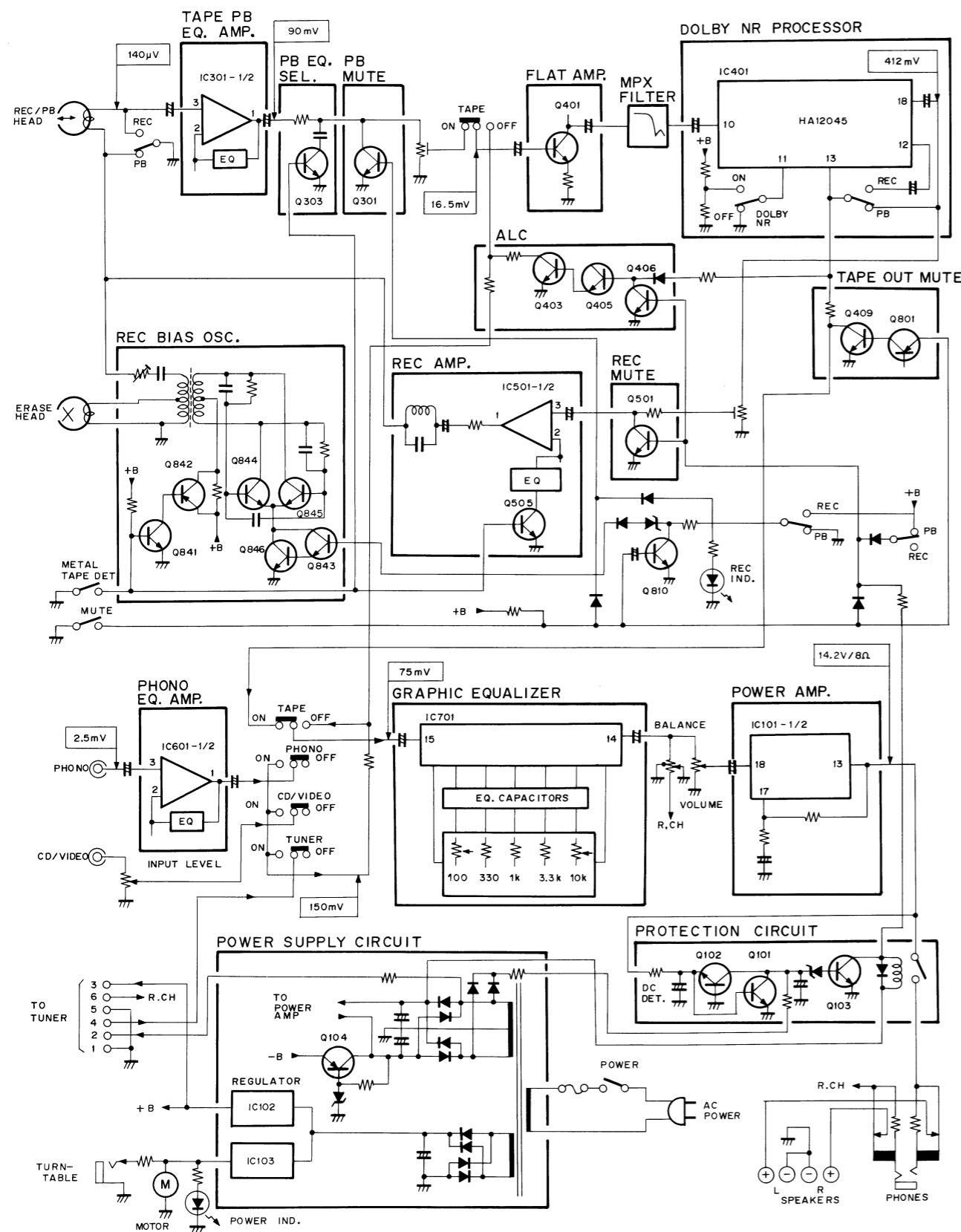

## 10. CIRCUIT DESCRIPTIONS

### 10-1. CASSETTE TAPE DECK SECTION

#### Playback Equalizer Section

The playback equalizer section employs a low noise operation amplifier IC (M5220L), and it provides a playback equalizer switchover circuit which operates by a transistor switch in the output circuit.

#### DOLBY NR Section

HA12045 which incorporates Type B DOLBY NR encoder/decoder in its L and R channels is used in this section.

#### Recording Amplifier Section

The operation amplifier IC (M5218L) is used in this section. It provides peaking circuits to the feedback loop, and the equalization for recording is performed by matching the tape to be used by selecting the peaking circuits with a transistor switch.

#### Automatic Tape Selector

It is designed for both metallic tape and normal tape uses. It enables to switchover record/playback equalizers and recording bias simultaneously by detecting the CrO<sub>2</sub> tape discrimination hole of the cassette half. Accordingly, when CrO<sub>2</sub> tape is used in playback, no particular problems will occur; however, when recording, the frequency characteristics tend to become over-bias. This results in much reduction of frequency characteristics in the higher ranges.

### 10-2. INTEGRATED AMPLIFIER SECTION

#### Phono Equalizer Amplifier Section

It uses a low noise operation amplifier IC (M5218P).

#### Graphic Equalizer Section

In order to vary the frequency characteristics, it provides five resonance circuits (to obtain equalized inductance by the transistors) in the feedback loop of the operation amplifier, and creates five poles in its playback signal frequency band. In each of these circuits, IC (BA3812L) is used. The IC (BA3812L) forms a five-pole graphic equalizer by adding a capacitor for resonance circuit and a variable resistor to it.

#### Power Amplifier Section

It uses IC (STK4141-2S) which incorporates a power amplifier for 2 channels and gains of 25W × 2 (THD 0.3% at 1 kHz).

#### Protection Circuit

It uses a relay to switch the output circuit of the power amplifier ON and OFF, and prevents the transient noise output due to cutoff by the DC voltage detection at the center of the output, and the delayed connection when the power is turned ON and instantaneous cutoff when the power is turned OFF.

## 11. ADJUSTMENT

### 11-1. MECHANICAL

#### Prior to Adjustment

Clean the both reel with an alcohol moist cloth.  
Pinch Roller Pressure  
1. Put the deck in the case.  
2. Gently push against the tension gauge and adjust from the capstan.  
3. Then the pinch roller read the value with the reading fails to pinch roller pressure.

# 11. ADJUSTMENTS

## 11-1. MECHANICAL ADJUSTMENTS

### Prior to Adjustment

Clean the both reel base, the capstan and the pinch roller with an alcohol moistened swab.

### Pinch Roller Pressure Adjustment

1. Put the deck in to the play back mode.
2. Gently push against the pinch roller arm with the tension gauge and separate the pinch roller slightly from the capstan.
3. Then the pinch roller back onto the capstan, and read the value when the pinch roller starts to rotate. If the reading fails to lie within 300 — 500g, replace the pinch roller pressure spring.

### Reel Base Torque Check

Measure the torque with the torque meter during playback, fast forward (FF) and rewind (REW) modes. The measured values should normally lie within the allowable ranges listed in the table 1. If the measured values lie outside the relevant ranges, replace the T reel assembly, and/or S reel assembly or P idler assembly.

Table 1

	T reel base (R side)	S reel base (L side)
PLAY mode	35g·cm — 70g·cm	*1g·cm — 5g·cm
FF mode	70g·cm — 140g·cm	*1g·cm — 5g·cm
REW mode	*1g·cm — 5g·cm	70g·cm — 140g·cm

\*back-tension torque

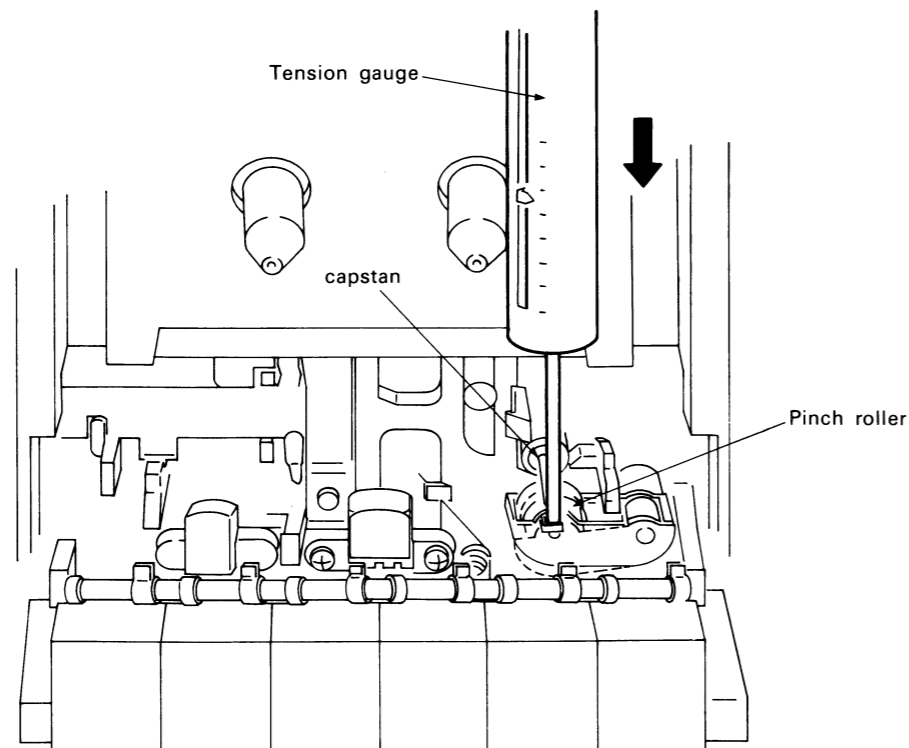

Fig. 11-1 Pinch Roller Pressure Adjustment

### Tape Speed Adjustment

1. Connect the frequency counter to the TP1 terminal on the Complex assembly.
2. Set the TAPE switch to the ON position.
3. Load the STD-301 test tape into the deck.
4. Check that the deck playback frequency is  $3010\text{Hz} \pm 5\text{Hz}$ .
5. If the frequency reading lies outside this range, adjust the semifixed resistor through the adjustment hole behind the motor to obtain the  $3010\text{Hz} \pm 10\text{Hz}$ .

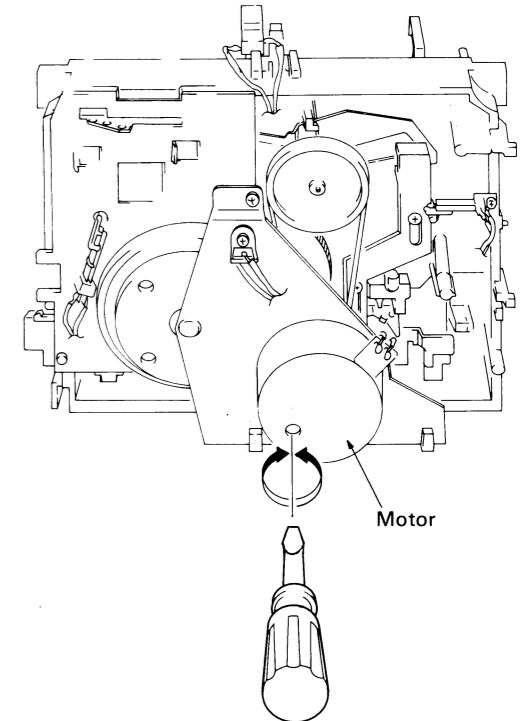

Fig. 11-2 Arrangement diagram of adjusting parts

### REC Joint Check

1. Check that the slide switch is fully switched when the tape transport unit is in the recording mode.
2. Move the REC joint mechanism catching position if the slide switch is not fully switched.

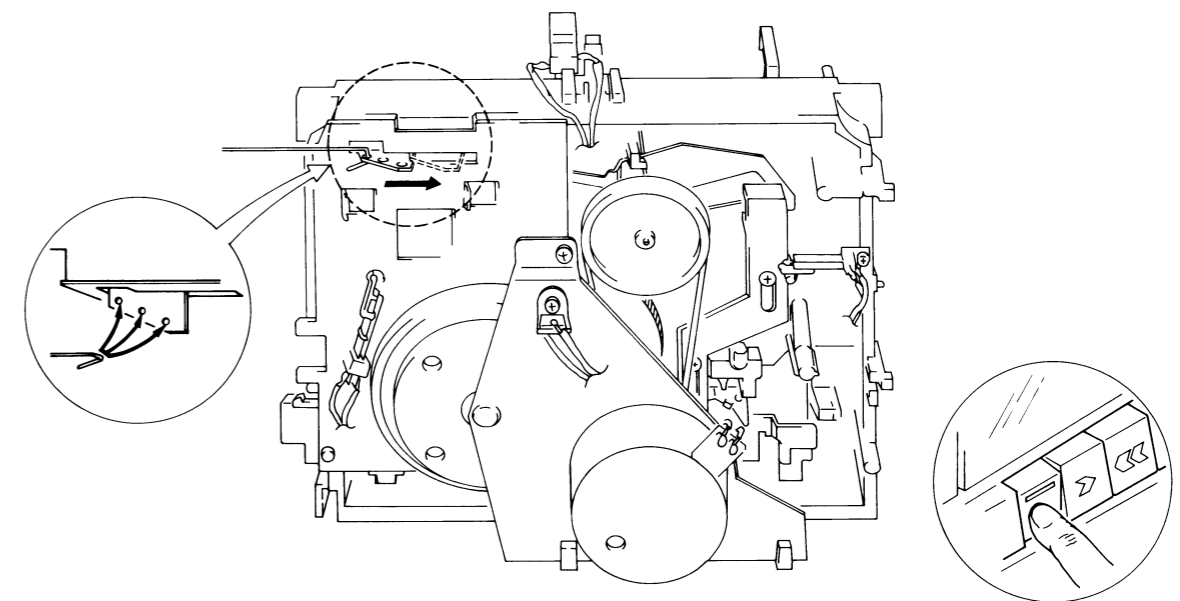

Fig. 11-3 REC joint adjustment



## 11-2. ELECTRICAL ADJUSTMENTS

Before commencing any electrical adjustments, make sure the following checked/completed.

1. All mechanical adjustments must have been completed.
2. The heads must be clean and demagnetized.
3. 0dB=1V during level measurements.
4. Use the specified tapes for each adjustment. Although test tapes have both A and B sides, only use side A where the label is attached.  
 STD-331B: Playback adjustment  
 STD-608A: NORMAL blank tape  
 STD-603: CrO<sub>2</sub> blank tape  
 STD-610: METAL blank tape
5. Prepare the following measuring equipment. AC millivoltmeter, audio generator, attenuator, oscilloscope.
6. Adjust both left and right channels unless otherwise specified.

7. And unless indicated otherwise, leave the DOLBY NR switch in the OFF position.
8. Let the set warm up for at least a few minutes before commencing adjustments. And before commencing the record/playback frequency response adjustment, let the set "age" for three to five minutes.
9. Always adjust the set in the given adjustments order. If the order is changed, proper adjustment will not be possible, and this may result in loss of performance.

### Adjustment Procedure

1. Head azimuth adjustment
2. Playback level adjustment
3. Recording/Playback frequency response
4. Recording level adjustment

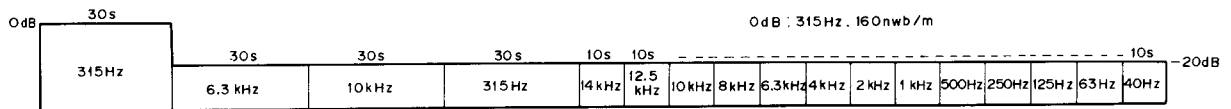

Fig. 11-4 Test tape STD-331B

• ADJUSTMENT (with auto tape selector function)							
<b>1. Head Azimuth Adjustment</b> • Set VR301 and VR302 (playback level adjustment) to MAX positions (turn fully clockwise)							
Tape selector	Mode	Input signal/test tape	Adjustment location	Measuring location	Adjustment value	Remarks	
NORM	PLAY	Play 10kHz-20dB portion of STD-331B test tape.	Head azimuth adjustment screw. (Fig. 11-5)	TP1 (L) TP2 (R)	Maximum playback signal level.	Apply "screw-lock" after completing adjustment.	
<b>2. Playback Level Adjustment</b> • Adjust precisely since this adjustment sets the playback Dolby level.							
Tape selector	Mode	Input signal/test tape	Adjustment location	Measuring location	Adjustment value	Remarks	
NORM	PLAY	Play the 315 Hz 0dB portion of the STD-331B test tape.	VR301 (L) VR302 (R)	TP1 (L) TP2 (R)	-7.7dBv (412mV)		
<b>3. Recording/Playback Frequency Response Adjustment</b>							
Tape selector	Mode	Input signal/test tape	Adjustment location	Measuring location	Adjustment value	Remarks	
NORM	REC	Apply a 315Hz signal to the CD/VIDEO terminals. Set the CD/VIDEO switch to ON.	1	TP1 (L) TP2 (R)	-27.7dBv (41mV)	Set the INPUT level control to the maximum position (rear panel).	
NORM	REC/PLAY	Record 315Hz and 6.3kHz signals on the STD-608A test tape, and then playback signals.	2	VR841 (L) VR842 (R)	TP1 (L) TP2 (R)	Repeat the recording and playback processes and adjust accordingly until the 6.3kHz playback level is within $0 \pm 0.5\text{dB}$ of the 315Hz level.	
• Change the test tape and the DOLBY NR switch position and check that the frequency response zone indicated in Fig. 11-8, 9 is satisfied.							
<b>4. Recording Level Adjustment</b>							
Tape selector	Mode	Input signal/test tape	Adjustment location	Measuring location	Adjustment value	Remarks	
NORM	REC	Apply a 315Hz signal to the CD/VIDEO terminals. Set the CD/VIDEO switch to ON.	1	TP1 (L) TP2 (R)	-7.7dBv (412mV)	Set the INPUT level control to the maximum position (rear panel).	
NORM	REC/PLAY	Record the 315Hz signal onto the STD-608A test tape, and then play the signal back.	2	VR501 (L) VR502 (R)	TP1 (L) TP2 (R)	Repeat the recording the playback processes, and adjust accordingly until a playback level of -7.7dBv (412mV) is obtained.	
METAL	REC/PLAY	Record the 315Hz signal onto the STD-610 test tape, and then play the signal back.	3	TP1 (L) TP2 (R)	Check that the 315Hz playback level is $-7.7\text{dBv} \pm 1.5\text{dB}$ .		

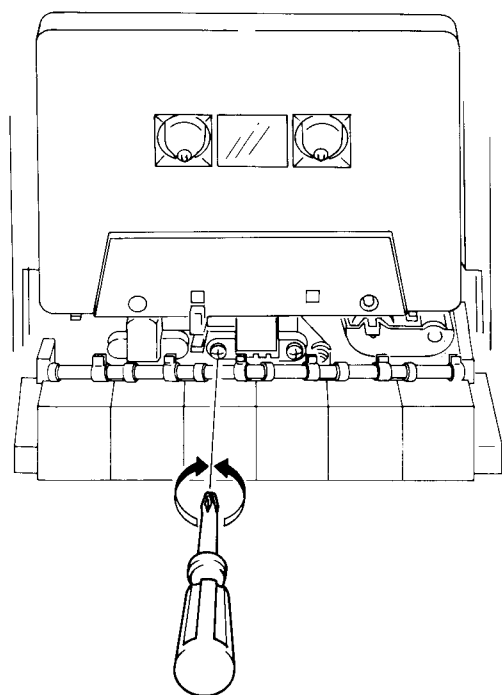

Fig. 11-5 Head azimuth adjustment

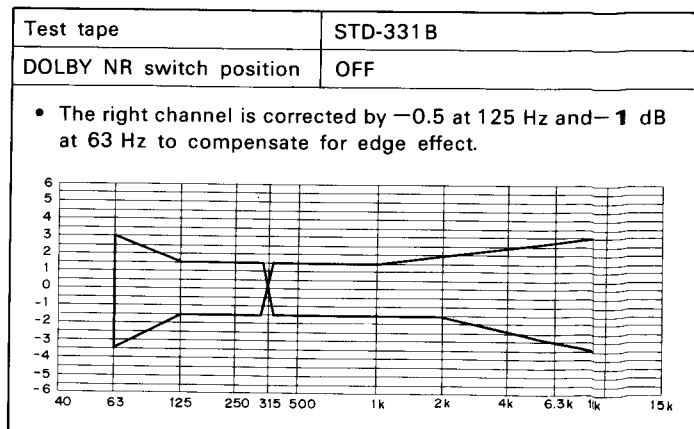

Fig. 11-6 Playback frequency response tolerance zone

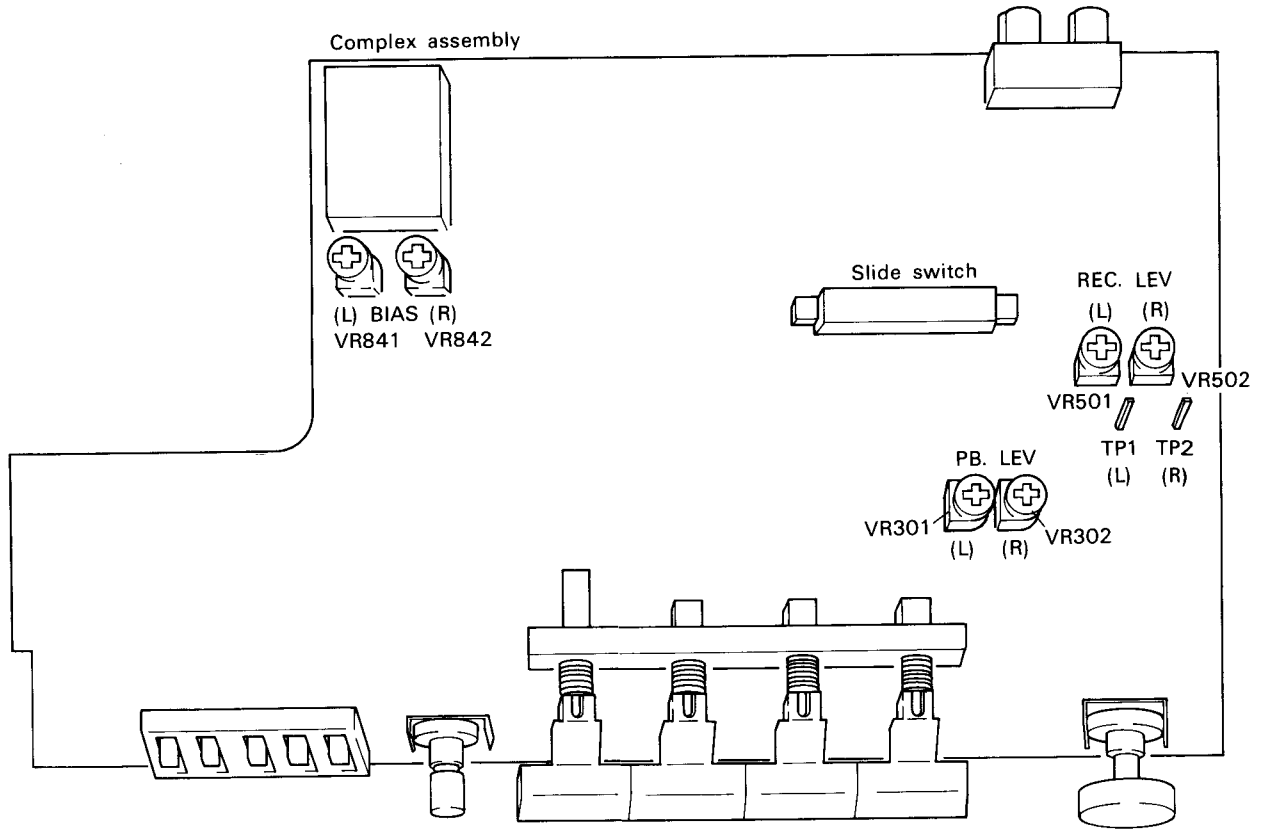

Fig. 11-7 Arrangement diagram of adjusting parts

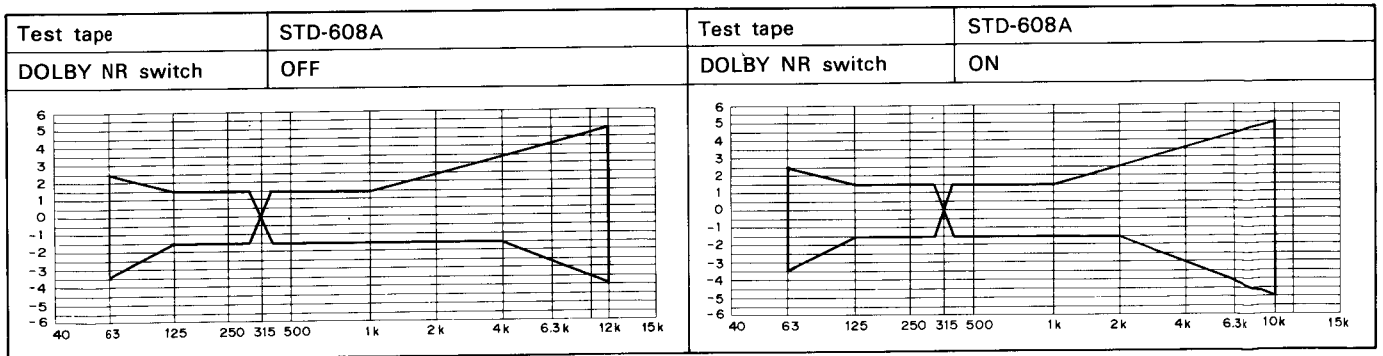

Fig. 11-8 Recording & playback frequency response tolerance zone (NORM)

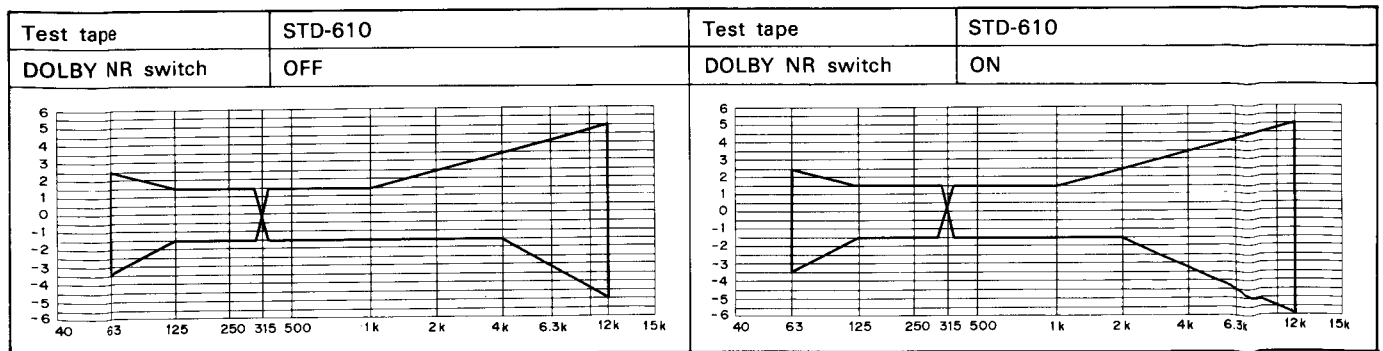

Fig. 11-9 Recording & playback frequency response tolerance zone (METAL)

# 11. RÉGLAGE

## 11-1. RÉGLAGES MECANQUES

### Avant le réglage

Nettoyer les deux embases de bobine, le cabestan et le rouleau presseur avec un tissu imbibé d'alcool.

### Réglage du rouleau presseur

1. Placer la platine en mode play back (lecture).
2. Pousser doucement la jauge de tension contre le bras du rouleau presseur et séparer légèrement le rouleau presseur du cabestan.
3. Puis, replacer le rouleau presseur contre le cabestan, et lire la valeur indiquée lorsque le rouleau presseur se met à tourner. Si la lecture est dans la plage 300 — 500g, remplacer le ressort du rouleau presseur.

### Vérification du couple d'embase de bobine

Mesurer la couple torsionmètre en modes, lecture, avance rapide (FF) et rembobinage (REW). Les valeurs mesurées devraient être comprises dans les plages indiquées dans le Tableau 1.

Si les valeurs mesurées ne sont pas comprises dans ces plages, remplacer le montage de bobine T, et/ou le montage de bobine S ou le montage de poulie intermédiaire P.

Tableau 1

	Embase de bobine T (côté droit)	Embase de bobine (côté gauche)
Mode PLAY	35g · cm—70g · cm	*1g · cm—5g · cm
Mode FF	70g · cm—140g · cm	*1g · cm—5g · cm
Mode REW	*1g · cm—5g · cm	70g · cm—140g · cm

\* Couple tension arrière

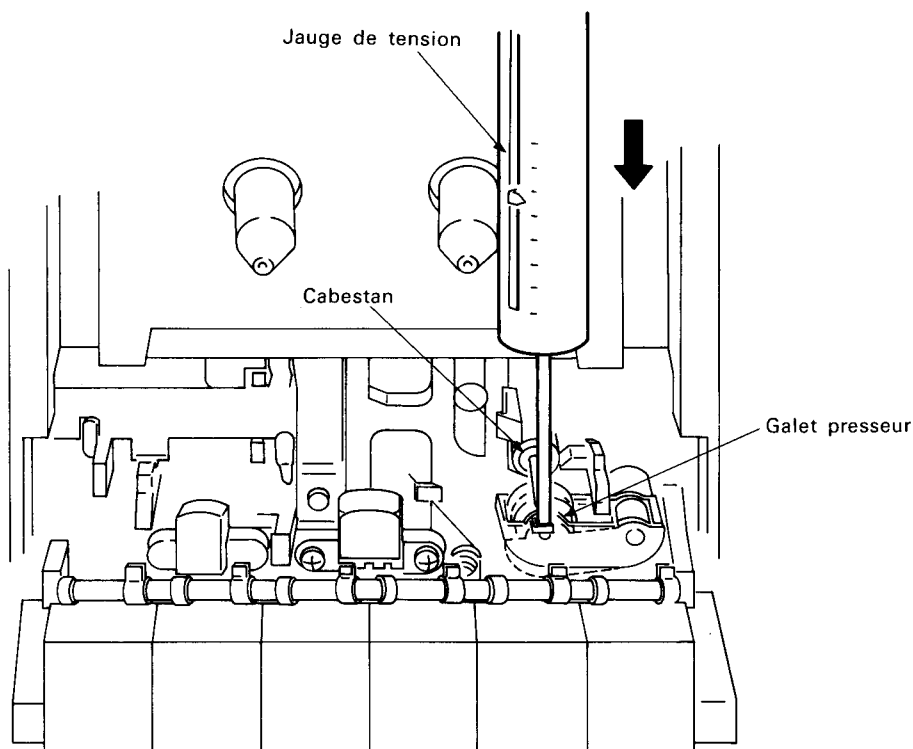

Fig. 11-1 Réglage du rouleau presseur

### Réglage de la vitesse de la bando

1. Connecter le fréquencemètre à la borne TP1 de l'ensemble.
2. Régler le commutateur TAPE en position ON.
3. Placer la bande-test STD-301 sur la platine.
4. Vérifier si la fréquence de lecture de la platine est de  $3010 \text{ Hz} \pm 5 \text{ Hz}$ .
5. Si la fréquence lue est en dehors de cette marge, régler la résistance semi-fixe par l'orifice de réglage situé à l'arrière du moteur pour obtenir  $3010 \text{ Hz} \pm 10 \text{ Hz}$ .

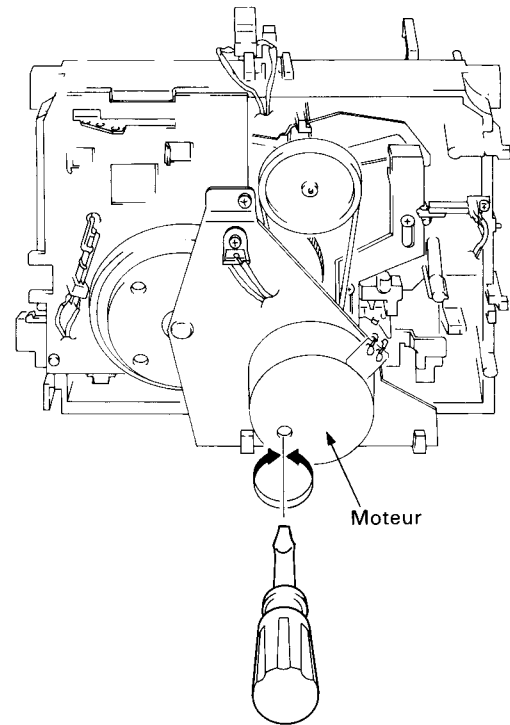

Fig. 11-2 Schéma de localisation des pièces de réglage

### Platine combinée REC

1. Vérifier que le commutateur coulissant est correctement en contact lorsque l'unité de transport de bande est en mode enregistrement.
2. Déplacer la position de prise du mécanisme combiné REC si le commutateur coulissant n'est pas correctement en contact.

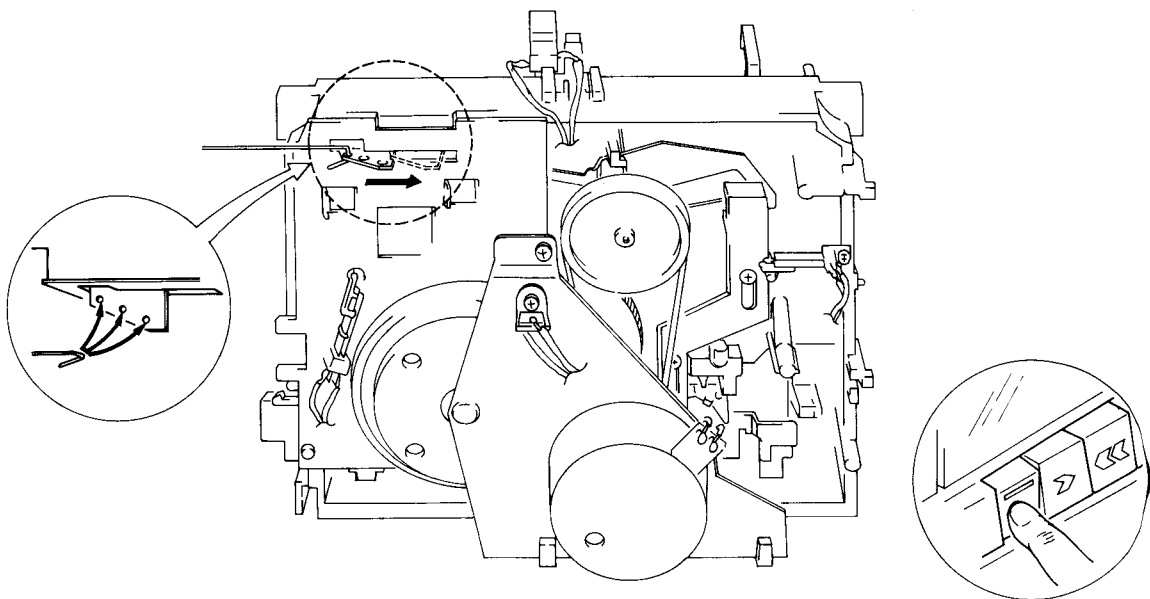

Fig. 11-3 Réglage mixte déenregistrement

## 11-2. RÉGLAGES ÉLECTRIQUES

■ Avant de commencer à procéder aux réglages électriques, bien effectuer les vérifications suivantes.

1. Tous les réglages mécaniques ont été effectués.
2. Les têtes doivent être propres et démagnétisées.
3. 0 dB=1V pendant les mesures de niveau.
4. Utiliser les bandes spécifiées pour chaque réglage. Bien que les bandes d'essai aient à la fois une face A et une face B, n'utiliser que la face A sur laquelle est attachée l'étiquette.  
 STD-331B: Réglage de la reproduction.  
 STD-608A: Bande vierge ordinaire (NORMAL)  
 STD-603: Bande vierge à l'oxyde de chrome (CrO<sub>2</sub>)  
 STD-610: Bande vierge au métal (METAL)
5. Préparer les équipements de mesure ci-après: millivoltmètre CA, générateur audio, atténuateur, oscilloscope.

6. Régler à la fois le canal gauche et le canal droit, sauf spécification contraire.
7. Sauf spécification contraire, laisser le commutateur de réduction de bruit DOLBY en position arrêt (OFF).
8. Laisser l'appareil chauffer pendant au moins quelques minutes avant de commencer les réglages. Avant de commencer le réglage de la réponse en fréquences enregistrement/reproduction, laisser l'appareil fonctionner de trois à cinq minutes.
9. Toujours procéder aux réglages dans l'ordre indiqué. Si cet ordre est modifié, il ne sera plus possible d'effectuer des réglages correctement, et cela pourrait entraîner une dégradation des performances.

### Procédure de réglage

1. Réglage de l'azimutage de la tête.
2. Réglage du niveau de reproduction.
3. Réponse en fréquences enregistrement/reproduction.
4. Réglage du niveau d'enregistrement.

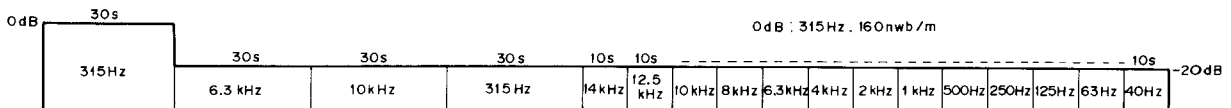

Fig. 11-4 Band d'essai STD-331B

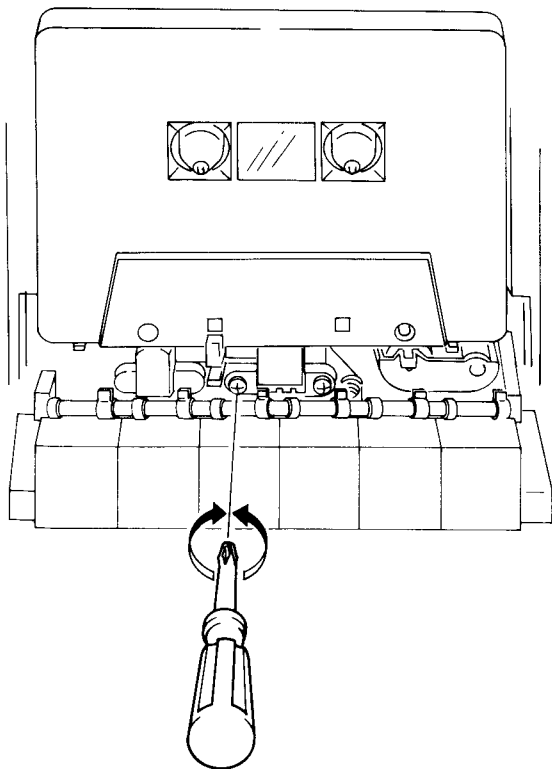

Fig. 11-5 Réglage d'azimut de la tête

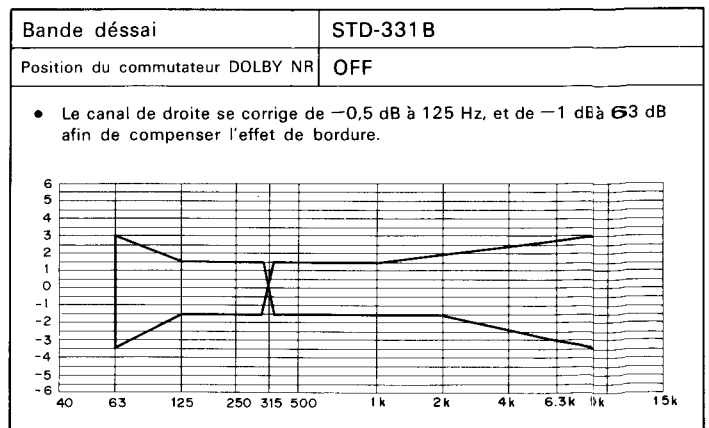

Fig. 11-6 Zone de tolérance de la réponse de fréquence de lecture

• RÉGLAGE (Avec sélecteur automatique de bande)						
<b>1. Réglage de l'azimutage de la tête</b> • Placer le VR301 et le VR302 (Réglage de niveau de reproduction) sur la position maximale (tourner complètement dans le sens des aiguilles d'une montre).						
Sélecteur de bande	Mode	Signal d'entrée/bande d'essai	Emplacement du réglage	Emplacement de mesure	Valeur de réglage	Remarques
Normal (NORM)	Reproduction (PLAY)	Reproduire la portion 10kHz -20dB de la bande d'essai STD-331B.	Vis de réglage de l'azimutage de la tête. (Fig. 11-5)	TP1 (L) TP2 (R)	Niveau de signal de reproduction maximal.	Mettre en place "l'arrêt de vis" après avoir effectué ce réglage.
<b>2. Réglage du niveau de reproduction</b> • Procéder à ce réglage avec précision car celui-ci détermine le niveau de reproduction du DOLBY.						
Sélecteur de bande	Mode	Signal d'entrée/bande d'essai	Emplacement du réglage	Emplacement de mesure	Valeur de réglage	Remarques
Normal (NORM)	Reproduction (PLAY)	Reproduire la portion 315Hz OdB de la bande d'essai STD-331B.	VR301 gauche (L) VR302 droit (R)	TP1 (L) TP2 (R)	-7,7dBv (412mV)	
<b>3. Réglage de la réponse en fréquences d'enregistrement et de reproduction</b>						
Sélecteur de bande	Mode	Signal d'entrée/bande d'essai	Emplacement du réglage	Emplacement de mesure	Valeur de réglage	Remarques
Normal (NORM)	Enregistrement (REC)	Appliquer un signal 315Hz aux bornes CD/VIDEO. Mettez le commutateur CD/VIDEO sur ON.	1 Entrer le signal de niveau à appliquer aux bornes de CD/VIDEO.	TP1 (L) TP1 (R)	-27,7dBv (41mV)	Amener la commande de niveau INPUT sur la position maximale (panneau arrière).
Normal (NORM)	Enregistrement/reproduction (REC/PLAY)	Enregistrer des signaux de 315Hz et 6,3kHz sur la bande d'essai STD-608A, et reproduire ensuite les signaux.	2 VR841 gauche (L) VR842 droit (R)	TP1 (L) TP2 (R)	Recommencer les procédures d'enregistrement et de reproduction, et procéder au réglage en conséquence jusqu'à ce que le niveau de reproduction du 6,3kHz soit compris entre 0 ±0,5dB du niveau du 315Hz.	
• Changer la bande d'essai et la position du commutateur de réducteur de bruit DOLBY, et vérifier que la courbe de réponse en fréquences indiquée sur la Fig. 11-8.9 est respectée.						
<b>4. Réglage du niveau d'enregistrement</b>						
Sélecteur de bande	Mode	Signal d'entrée/bande d'essai	Emplacement du réglage	Emplacement de mesure	Valeur de réglage	Remarques
Normal (NORM)	Enregistrement (REC)	Appliquer un signal 315Hz aux bornes CD/VIDEO. Mettez le commutateur CD/VIDEO sur ON.	1 Entrer le signal de niveau à appliquer aux bornes de CD/VIDEO.	TP1 (L) TP2 (R)	-7,7dBv (412mV)	Amener la commande de niveau INPUT sur la position maximale (panneau arrière).
Normal (NORM)	Enregistrement/reproduction (REC/PLAY)	Enregistrer le signal de 315Hz sur la bande d'essai STD-608A, puis reproduire le signal.	2 VR501 gauche (L) VR502 droit (R)	TP1 (L) TP2 (R)	Recommencer les procédures d'enregistrement et de reproduction, et procéder au réglage jusqu'à ce que un niveau de reproduction de -7,7dBv (412mV) soit obtenu.	
Métal (METAL)	Enregistrement/reproduction (REC/PLAY)	Enregistrer le signal de 315Hz sur la bande d'essai STD-610, puis reproduire le signal.	3	TP1 (L) TP2 (R)	Vérifier que le niveau de reproduction du 315Hz est à -7,7dBv ± 1,5dB.	

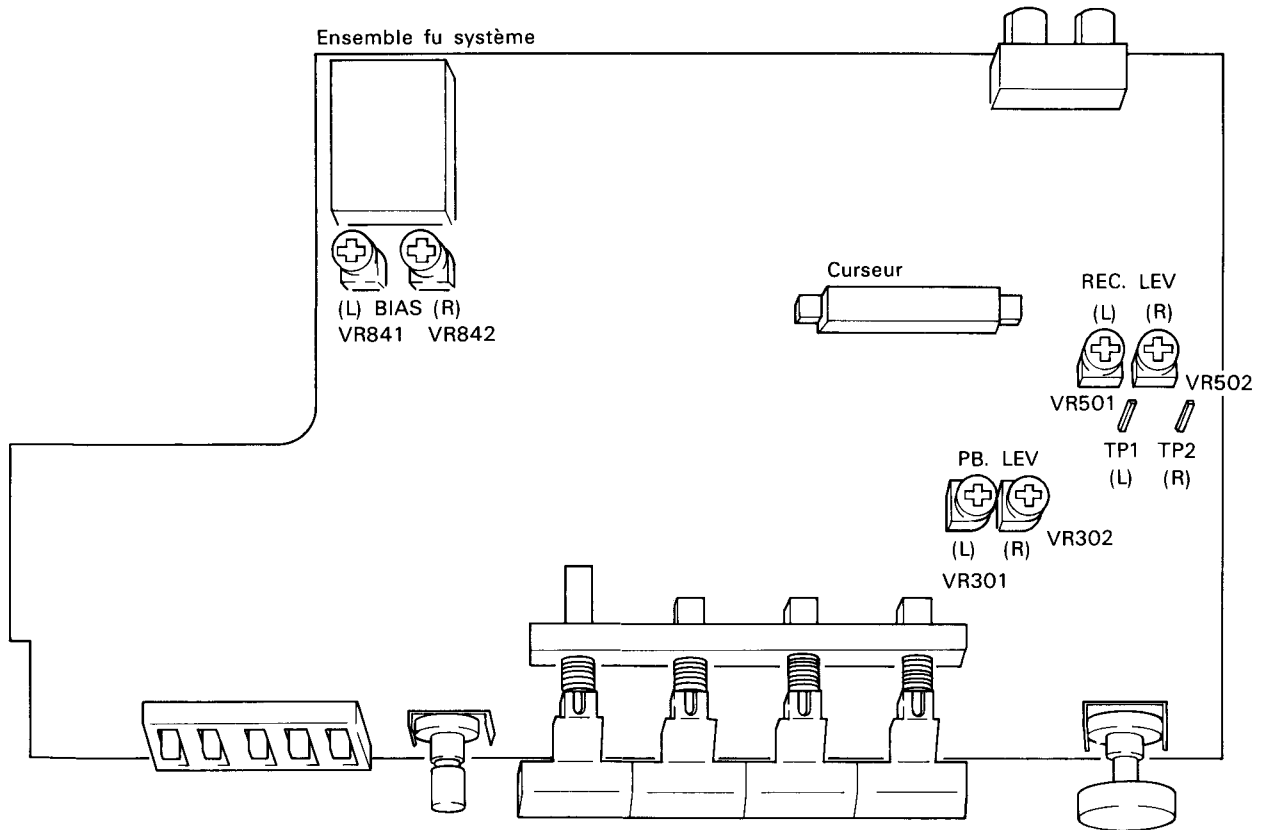

Fig. 11-7 Shéma de localisation des pièces de réglage

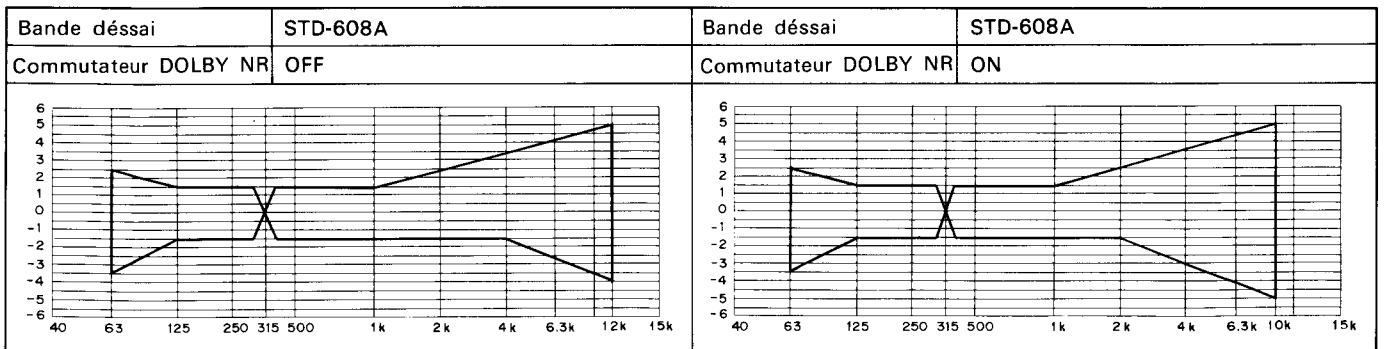

Fig. 11-8 Zone de tolérance de la réponse de fréquence d'enregistrement et de lecture (NORM)

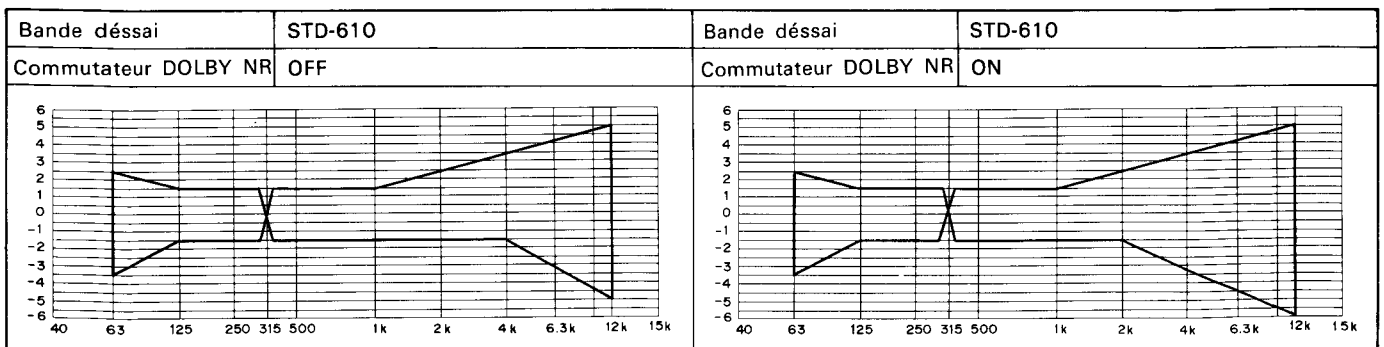

Fig. 11-9 Zone de tolérance de la réponse de fréquence d'enregistrement et de lecture (METAL)



## 11. AJUSTE

### 11-1. AJUSTES MECANICOS

#### Antes del ajuste

Limpie ambas bases del carrete, el cabrestante y el rodillo de prensado con una escobillón humedecido en alcohol.

#### Ajuste de la presión del rodillo de prensado

1. Ponga el magnetofono en el modo de reproducción.
2. Suavemente empuje en contra del brazo del rodillo de prensado con el indicador de tensión y separe el rodillo de prensado ligeramente del cabrestante.
3. Luego ponga de nuevo el rodillo de prensado en el cabrestante, y lea la lectura cuando el rodillo de prensado empiece a girar.

Si la lectura no está dentro de 300 a 500g, cambie el resorte de presión del rodillo de prensado.

#### Inspección del par de torsión de la base de carrete

Mida el par de torsión con un medidor de par de torsión durante la reproducción, en los modos de avance rápido (FF) y rebobinado (REW). Los valores medidos deberán normalmente estar dentro de los rangos permisibles enlistados en la table 1.

Si los valores medidos están fuera de los rangos pertinentes, cambie el conjunto del carrete T, y/o el conjunto del carrete S o el conjunto de la rueda loca P.

Tabla 1

	Base del carrete T (lado R)	Base del carrete S (lado L)
Mode PLAY	35g·cm—70g·cm	*1g·cm—5g·cm
Mode FF	70g·cm—140g·cm	*1g·cm—5g·cm
Mode REW	*1g·cm—5g·cm	70g·cm—140g·cm

\* Par de contra tensión

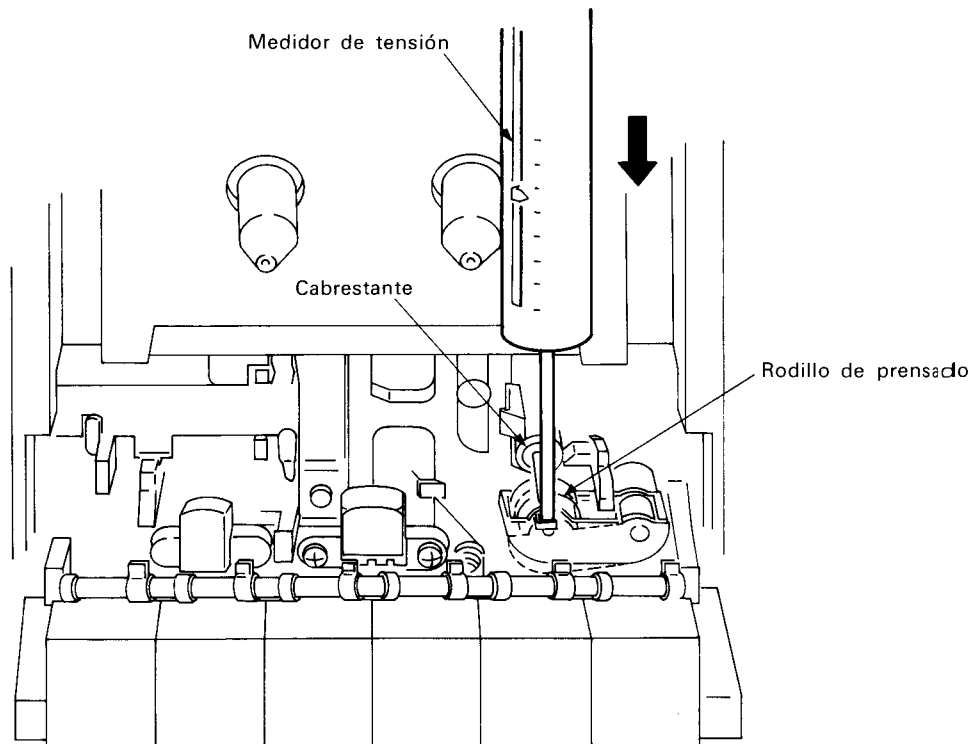

Fig. 11-1 Ajuste de la presión del rodillo de prensado

**Ajuste de la velocidad de cinta**

1. Conecte el frecuencímetro a la terminal TP1 en el conjunto compuesto.
2. Fije el interruptor de TAPE a la posición ON.
3. Introduzca la cinta de prueba STD-301 en el magnetofono.
4. Inspeccione que la frecuencia de reproducción sea  $3010 \text{ Hz} \pm 5 \text{ Hz}$ .
5. Si la lectura de la frecuencia está fuera de este rango, ajuste el resistro semifijado a través del orificio de ajuste localizado detras del motor para obtener  $3010 \text{ Hz} \pm 10 \text{ Hz}$ .

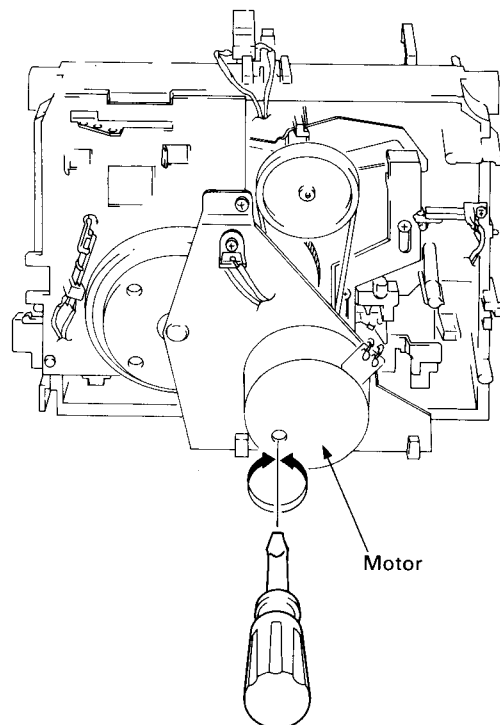

Fig. 11-2 Diagrama de disposición de las partes de ajuste

**Inspección de la unión REC**

1. Inspeccione que el interruptor deslizable este cambiado completamente cuando la unidad de transporte de la cinta está en el modo de grabación.
2. Mueva la posición de trabado del mecanismo de unión REC si el interruptor deslizable no esta completamente cambiado.

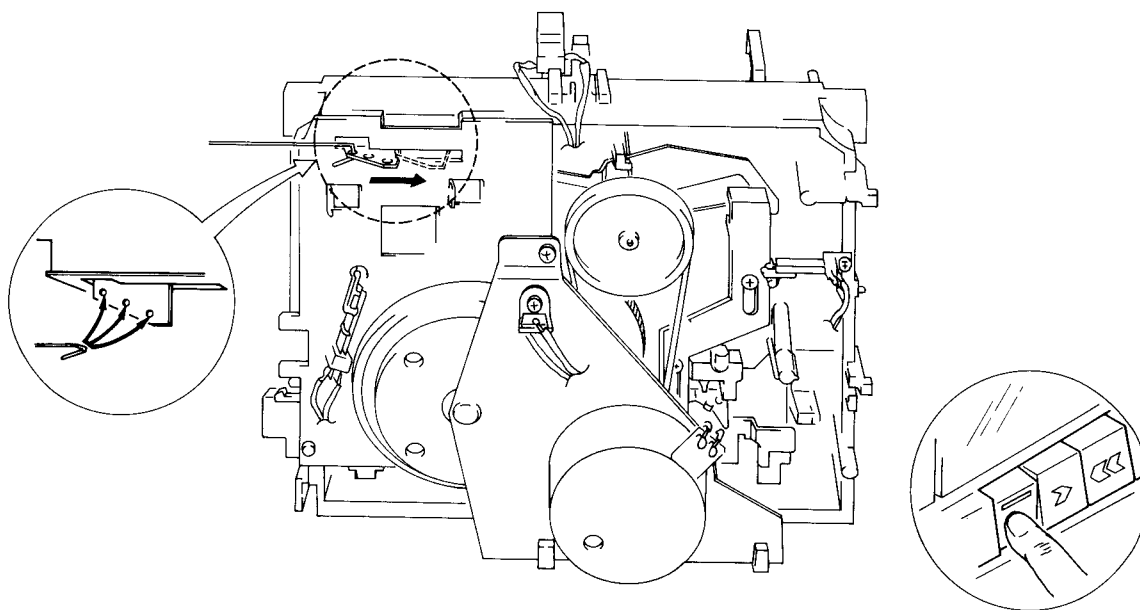

Fig. 11-3. Ajuste de la unión de REC

### 11-2. AJUSTES ELECTRICOS

■ **Antes de iniciar cualquier ajuste, cerciorarse de haber completado y comprobado lo siguiente.**

1. Deben haberse completo todos los ajustes mecánicos.
2. Las cabezas deben estar limpias y desmagnetizadas.
3. 0 dB=1V durante las mediciones del nivel.
4. Emplear las cintas especificadas para cada ajuste. Aunque estas cintas están provistas de ambos lados, A y B, emplear sólo el lado A, donde está la etiqueta.  
 STD-331B: Ajuste de reproducción.  
 STD-608A: Cinta en blanco NORMAL.  
 STD-603: Cinta en blanco de CrO<sub>2</sub>.  
 STD-610: Cinta en blanco de METAL.
5. Preparar el siguiente equipo de medición: Un voltímetro de CA, un generador de sonido, un atenuador y un osciloscopio.
6. Ajustar los canales izquierdo y derecho a menos que se especifique lo contrario.

7. Y a menos que se diga lo contrario, dejar el interruptor DOLBY NR en la posición OFF.
8. Dejar que se precaliente el aparato durante algunos minutos antes de iniciar los ajustes.  
 Y antes de empezar el ajuste de la respuesta en frecuencia para reproducción y grabación, dejar que se precaliente de tres a cinco minutos.
9. Ajustar siempre el aparato en el orden de ajuste dado. Si se cambia el orden, no son posibles los ajustes adecuados, lo cual puede ocasionar pérdida del rendimiento.

#### Procedimientos de ajuste

1. Ajuste del acimut de la cabeza.
2. Ajuste del nivel de reproducción.
3. Respuesta en frecuencia de grabación/reproducción.
4. Ajuste del nivel de grabación.

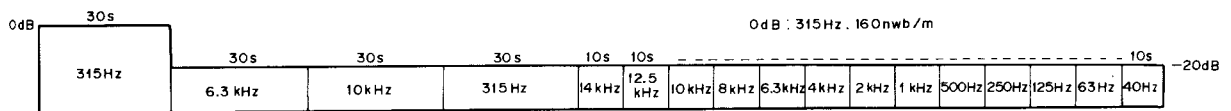

Fig. 11-4. Cinta de prueba STD-331B

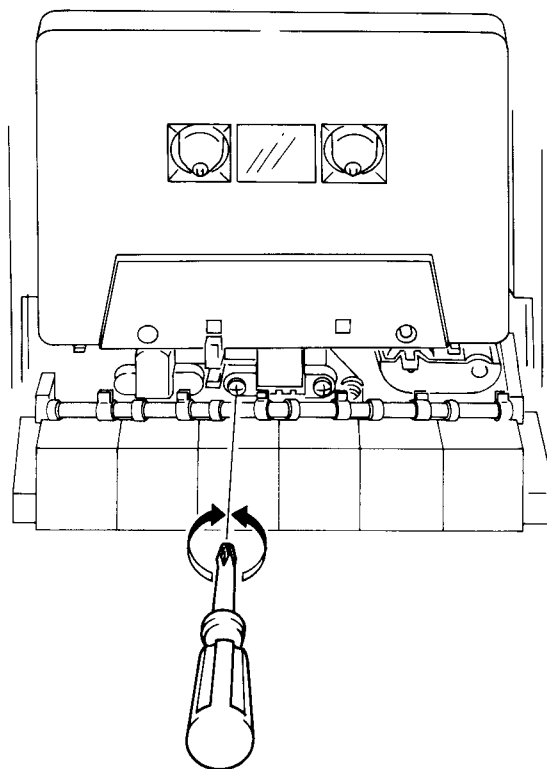

Fig. 11-5 Ajuste del acimut de la cabeza

• AJUSTE (Con la función del selector automático de cintas)						
<b>1. Ajuste del acimut de la cabeza</b> • Ajustar VR301 y VR302 (Ajuste del nivel de reproducción) a las posiciones MAX (Girados completamente a la derecha)						
Selector de cintas	Modo	Señal de entrada/cinta de prueba	Lugar de ajuste	Lugar de medición	Valor de ajuste	Observaciones
NORM	PLAY	Reproducir la parte de 10kHz -20dB de la cinta de prueba STD-331B.	Tornillo de ajuste del acimut de la cabeza. (Fig. 11-5)	TP1 (L) TP2 (R)	Nivel máximo de la señal de reproducción.	Aplicar el "enclavamiento del tornillo" después de terminar el ajuste.
<b>2. Ajuste del nivel de reproducción</b> • Ajustar con precisión porque este ajuste establece el nivel del sistema Dolby de reproducción.						
Selector de cintas	Modo	Señal de entrada/cinta de prueba	Lugar de ajuste	Lugar de medición	Valor de ajuste	Observaciones
NORM	PLAY	Reproducir la parte de 315Hz 0dBv de la cinta de prueba STD-331B.	VR301 (L) VR302 (R)	TP1 (L) TP2 (R)	-7,7dBv (412mV)	
<b>3. Ajuste de la respuesta en frecuencia para grabación/reproducción</b>						
Selector de cintas	Modo	Señal de entrada/cinta de prueba	Lugar de ajuste	Lugar de medición	Valor de ajuste	Observaciones
NORM	REC	Aplique una señal de 315Hz a las terminales CD/VIDEO. Fije el interruptor de CD/VIDEO a ON.	Nivel de señal de entrada a ser aplicada a las terminales CD/VIDEO.	TP1 (L) TP2 (R)	-27,7dBv (41mV)	Fije el control de nivel de INPUT (entrada) a la posición máxima (panel trasero).
NORM	REC/PLAY	Grabar las señales de 315Hz y de 6,3kHz en la cinta de prueba STD-608A, y luego reproducirlas.	VR841 (L) VR842 (R)	TP1 (L) TP2 (R)	Repetir los procesos de grabación y reproducción y ajustar consecuentemente hasta que el nivel de reproducción de 6,3kHz esté dentro de $0 \pm 0,5dB$ del nivel de 315Hz.	
• Cambiar la cinta de prueba y la posición del interruptor DOLBY NR y comprobar que la zona de respuesta en frecuencia indicada en la Fig. 11-8, 9 se satisfaga.						
<b>4. Ajuste del nivel de grabación</b>						
Selector de cintas	Modo	Señal de entrada/cinta de prueba	Lugar de ajuste	Lugar de medición	Valor de ajuste	Observaciones
NORM	REC	Aplique una señal de 315Hz a las terminales CD/VIDEO. Fije el interruptor de CD/VIDEO a ON.	Nivel de señal de entrada a ser aplicada a las terminales CD/VIDEO.	TP1 (L) TP2 (R)	-7,7dBv (412mV)	Fije el control de nivel de INPUT (entrada) a la posición máxima (panel trasero).
NORM	REC/PLAY	Grabar la señal de 315Hz en la cinta de prueba STD-608A y reproducirlas.	VR501 (L) VR502 (R)	TP1 (L) TP2 (R)	Repetir los procesos de grabación y ajustar consecuentemente hasta que se obtenga un nivel de reproducción de -7,7dBv (412mV).	
METAL	REC/PLAY	Grabar la señal de 315Hz en la cinta de prueba STD-610 y reproducirla.		TP1 (L) TP2 (R)	Comprobar que el nivel de reproducción de 315Hz sea de $-7,7dBv \pm 1,5dB$ .	

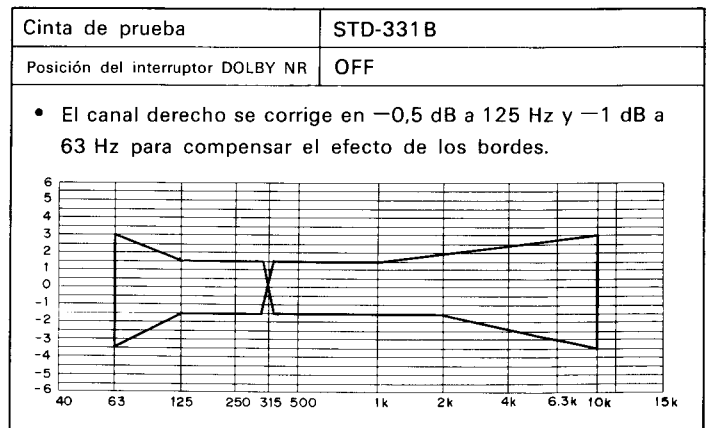

Fig. 11-6 Zona de tolerancia de respuesta de frecuencia de reproducción

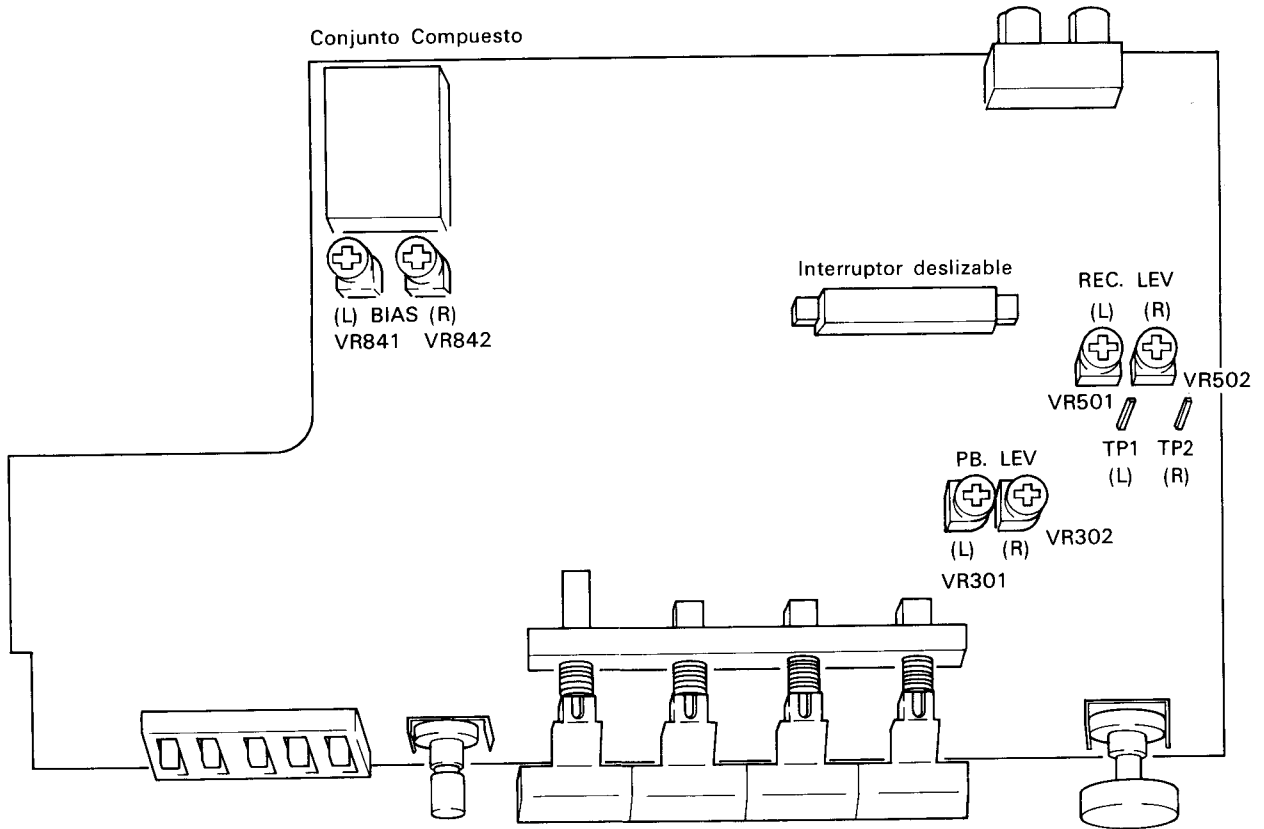

Fig. 11-7 Diagrama de disposición de las partes de ajuste

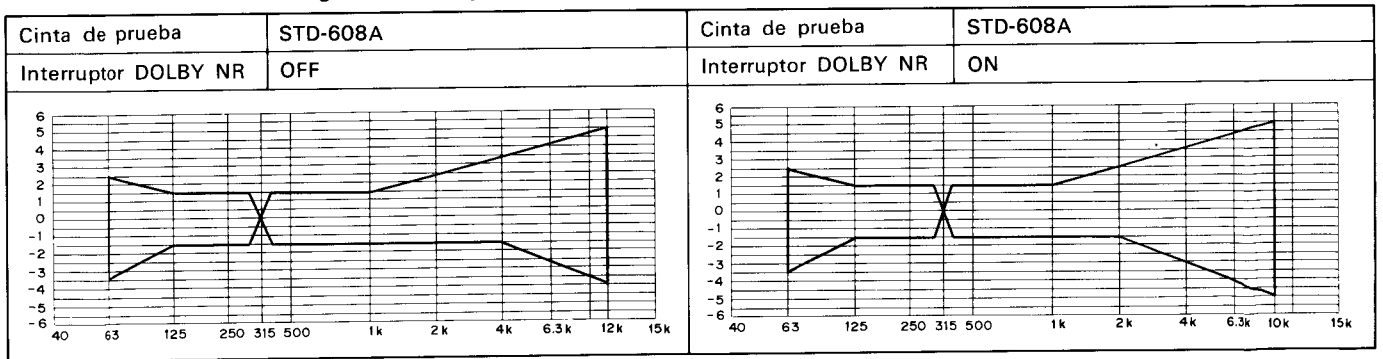

Fig. 11-8 Zona de tolerancia de copia y respuesta de frecuencia de reproducción (NORM)

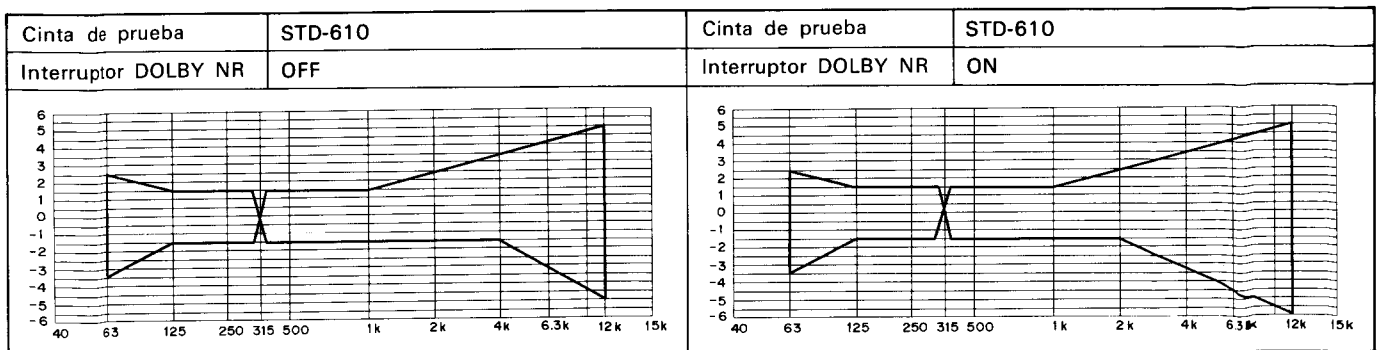
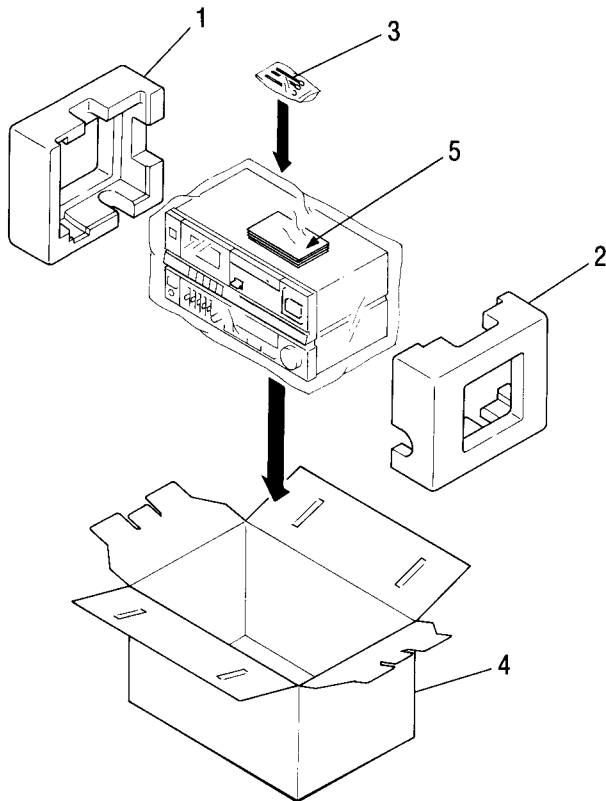

Fig. 11-9 Zona de tolerancia de copia y respuesta de frecuencia de reproducción (METAL)

## 12. PACKING



Mark	No.	Part No.	Description
	1	AHA-395	Side pad L
	2	AHA-396	Side pad R
	3	AEX-016	Head swab
	4	AHE-476	Packing case for DC-X11Z
		AHE-472	Packing case for DC-X10Z
	5	ARB-645 (HB type)	Operating instructions (English)
		ARE-127 (HE type)	Operating instructions (English/German/French/Italian)

### Line Voltage Selection

#### Line Voltage Selection for HE and HB Types

1. Disconnect the AC power cord.
2. Remove the bonnet case.
3. Change the connection of the power transformer primary lead wire as follows:
  - 220V: Disconnect the terminal no.2 on the fuse holder assembly to the terminal no.8 of the power transformer, and connect the terminal no.2 on the fuse holder assembly to the terminal no.6 of the power transformer.
  - 240V: Disconnect the terminal no.2 on the fuse holder assembly to the terminal no.6 of the power transformer, and connect the terminal no.2 on the fuse holder assembly to the terminal no.8 of the power transformer.
4. Stick the line voltage label on the rear panel.

Description	Part No.
220V label	AAX-193
240V label	AAX-192